

UL 580 CLASS 90 RATED PRODUCT ASSEMBLIES

CONSTRUCTION NO. 403 - Galvalume® BERRIDGE ZEE-LOCK PANEL WITH INDIVIDUAL CLIPS OVER 5/8" PLYWOOD

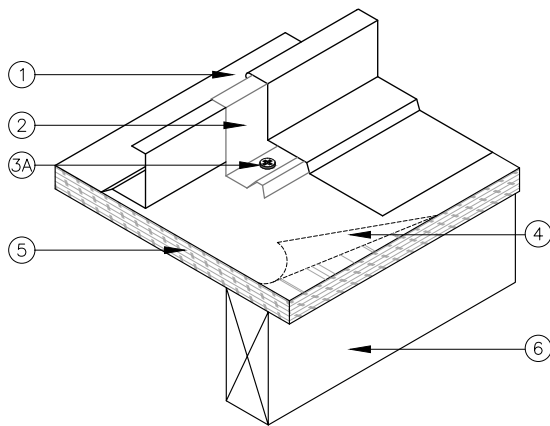

- BERRIDGE ZEE-LOCK PANEL:** No. 24 MSG (Min. yield strength 40,000 PSI) thickness coated steel, 16" wide, 2" high panel continuous over 2 or more spans without endlaps. An optional extruded vinyl weatherseal (U.S. Patent 5134825) may be used at panel side joints. Adjacent panels are seamed together alongside joints using an electric seamer tool.
- BERRIDGE ZEE-CLIP:** One-piece, 2" high and 3" long, assembly fabricated from No. 24 MSG (Min. yield strength 40,000 PSI) coated steel. Zee-Clip located 36" on center at each panel side joints.
- FASTENERS (SCREWS):**
 - For Connection of Item #2 to Item #5:** #10 x 1" long pan head steel screws. Two per clip
 - For Connection of Item #5 to Item #6 (Not Shown):** #8 x 1 1/2" long pan head wood screw spaced 12" on center at plywood to joist connection and at plywood ends.
- FELT PAPER:** Two ply, No. 30 lb per 100 sq. ft.
- SUBSTRUCTURE (PLYWOOD):** Nominal 5/8" thick, exposure sheathing span C-D 40/20 plywood.
- JOISTS:** Nominal 2" x 4" at maximum 2'0" on center

BERRIDGE MANUFACTURING COMPANY

2610 Harry Wurzbach Road, San Antonio, TX 78209 | 800-669-0009 | Fax 210-650-0379

Visit www.berridge.com for the most up-to date information. All information herein subject to change without notice. For technical assistance please contact Berridge.