

UL 580 CLASS 90 RATED PRODUCT ASSEMBLIES

CONSTRUCTION NO. 30 BERRIDGE "R" PANEL THROUGH 4" BLANKET INSULATION INTO OPEN PURLINS

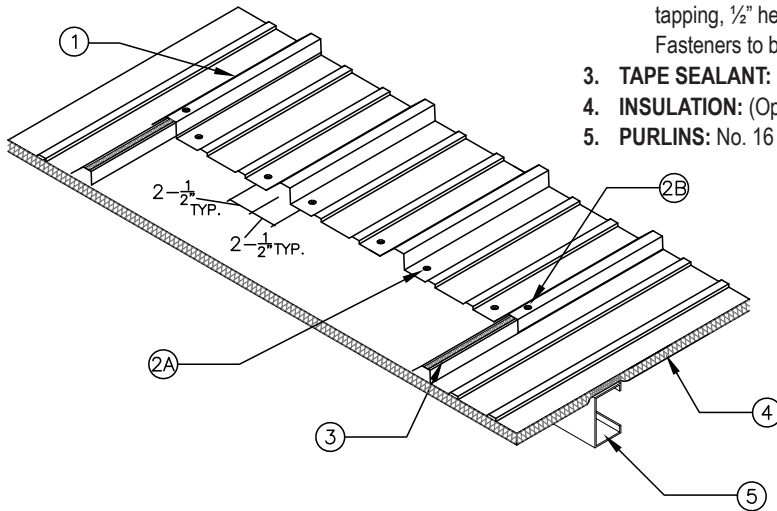

- BERRIDGE "R" PANEL:** No. 24 MSG (Min. yield strength 40,000 PSI) thickness coated steel, 36" wide, 1 1/4" high rib panel continuous over two or more spans. Endlaps to occur over purlins with panels overlapped 3" minimum, 6" maximum with lap beginning even with purlin web and extending across purlin flange. A line of tape sealant (Item 3) may be used at panel side and end laps.
- FASTENERS (SCREWS):**
 - For Connection of Item #1 to Item #5:** #12-14 self-drilling, self-tapping, 1/2" hexhead Type B steel or stainless steel screw with neoprene washer. Fasteners to be at panel and purlin intersection and have a 4-8-4-8 pattern located 2" from the center line on both sides of each major rib.
 - For Connection of Item #1 to Item #1 (Panel Lap):** #12-14 self-drilling, self-tapping, 1/2" hexhead Type B steel or stainless steel screw with neoprene washer. Fasteners to be 20" on center.
- TAPE SEALANT:** Used along panel side laps and endlaps for watertightness
- INSULATION:** (Optional) 4" Vinyl Faced compressible insulation
- PURLINS:** No. 16 MSG (Min. yield strength 50,000 PSI), maximum 5'0 spacing

BERRIDGE MANUFACTURING COMPANY

2610 Harry Wurzbach Road, San Antonio, TX 78209 | 800-669-0009 | Fax 210-650-0379

Visit www.berridge.com for the most up-to date information. All information herein subject to change without notice. For technical assistance please contact Berridge.