

# OPERATIONS MANUAL

# BERRIDGE ZEE-LOCK DOUBLE-LOCK SEAMER

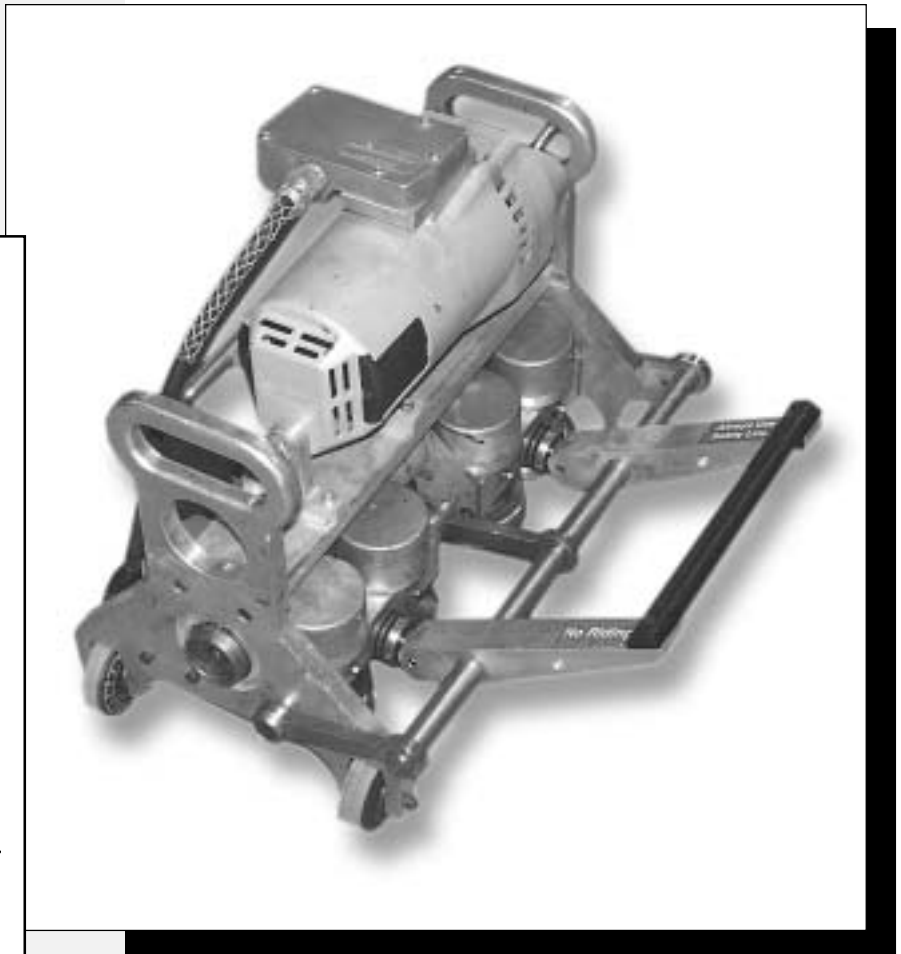
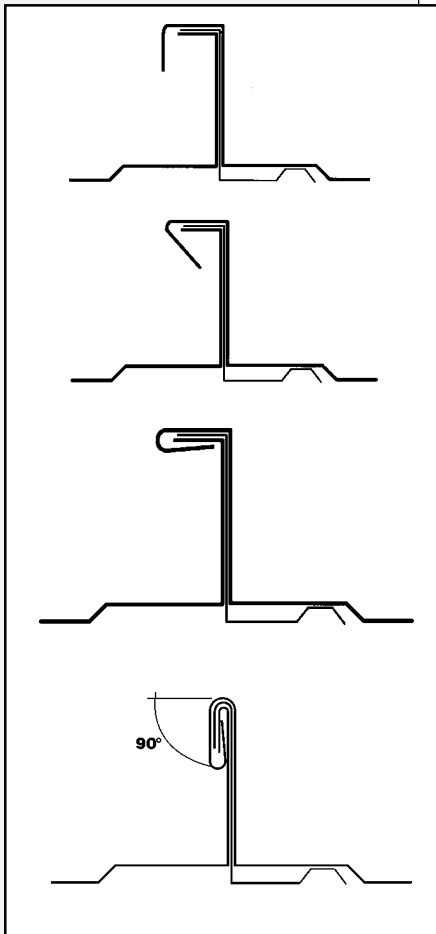

**BERRIDGE**  
**B** Berridge  
Manufacturing  
Company  
*Roofs of Distinction*

OWNER: \_\_\_\_\_

\_\_\_\_\_

\_\_\_\_\_

DATE: \_\_\_\_\_ SER. NO.: \_\_\_\_\_

# CONTENTS

---

I. GENERAL DESCRIPTION ..... 2

II. EQUIPMENT NOMENCLATURE, FEATURES & SPECIFICATIONS ..... 3

III. OPERATING INSTRUCTIONS ..... 4-5

IV. MAINTENANCE INSTRUCTIONS ..... 5

VI. SAFETY ..... 5

VII. SEAMER RETURN FORM ..... 6

---

## I. GENERAL DESCRIPTION

THE BERRIDGE DOUBLE-LOCK ZEE-LOCK Seamer is a precision-manufactured machine designed to provide uniform, high-quality double-lock seaming capability for installers of the BERRIDGE ZEE-LOCK Standing Seam Roof panel (fig. 1).

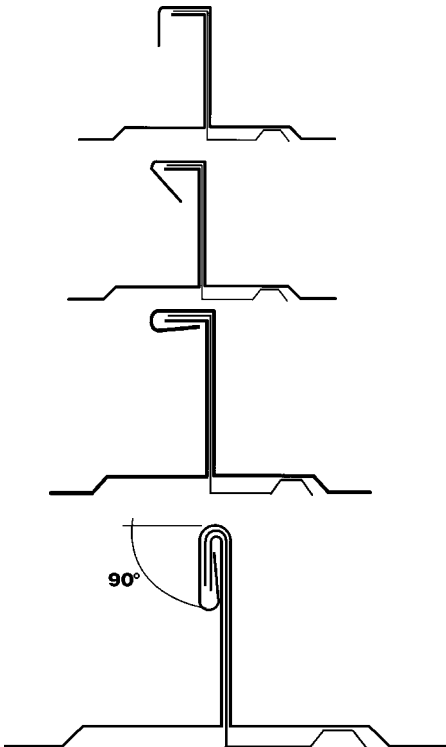

### ELECTRICAL POWER REQUIREMENTS:

The Berridge ZEE-LOCK DOUBLE LOCK SEAMER requires standard U.S. electrical current of 110 to 120 volts AC 60 cycles. Connect to a grounded supply receptacle with at least 15 amp current capacity. If extension cords are required, use the following recommended sizes:

LENGTH	WIRE GAUGE
0-150 ft. ....	14
150-200 ft. ....	12
200 ft. + .....	10

# EQUIPMENT NOMENCLATURE: ZEE-LOCK DOUBLE-LOCK SEAMER

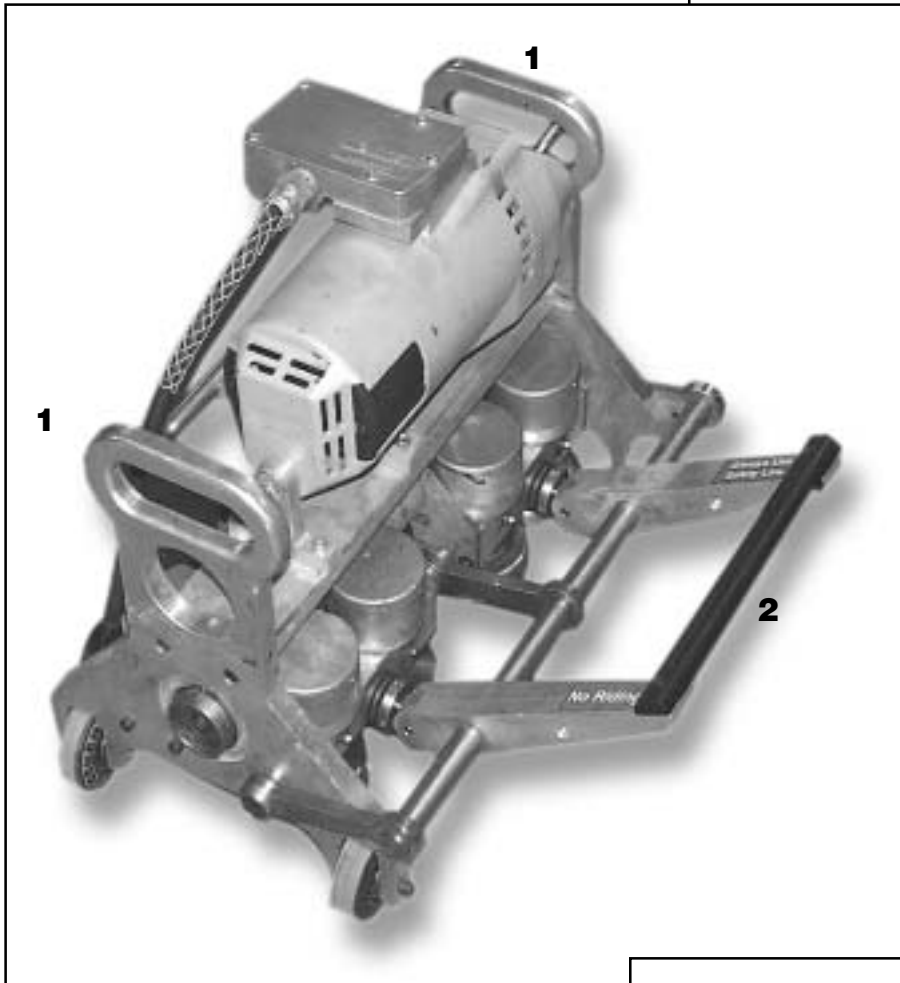

## COMPONENTS:

1. Carrying Handle
2. Die Lever Handle
3. On/Off Switch
4. Die Assembly Top Plate
5. Roller Dies
6. Idler Guide Wheels

## ZEE-LOCK DOUBLE LOCK SEAMER FEATURES:

- Seams in one pass
- Seamer will run in one direction only. Seaming direction is indicated by an arrow on top of the seamer.
- Rubber forming rollers must be located on flat side of seam.
- Heat-treated stainless steel rollers to prevent marring panel
- Maximum Gauge = 24 ga.  
Consult BMC for 22 ga.

## SPECIFICATIONS

Weight .... 80 lbs  
Speed ..... 30 ft. per minute

## POWER

Motor ..... 10 amps  
Phase ..... Single  
Volts ..... 120 volt

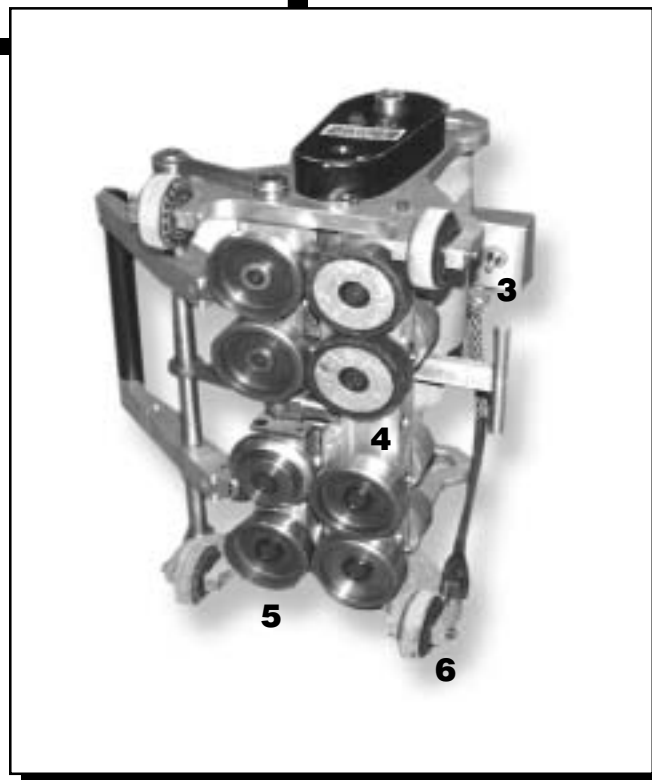

### III. OPERATING INSTRUCTIONS

1. After you have fabricated the Zee-Lock panels and installed the required accessories at gables and eave flashing (see the Berridge Technical Manual, Zee-Lock Installation Instructions and Typical Installation Details), place the first Zee-Lock Panel at one gable end.
2. Remove strippable film from all panel surfaces, including the edges of both seam legs BEFORE installing panels.



FIG. 1 - USE THE SINGLE-LOCK HAND CRIMPER FIRST...



FIG. 2 - ...THEN COMPLETE HAND CRIMPING WITH THE DOUBLE-LOCK HAND CRIMPER

3. Install either the Continuous Zee-Rib along the leading male leg of the first Zee-Lock panel or Zee-Lock Clips at required spacing.
4. Prepare the sidelap seam for machine seaming by crimping the starting end of the side lap using the Zee-Lock Hand Crimper Tool. From the starting end of seam, hand crimp about 24" of the seam with the Single Lock Hand Crimper (Fig. 1). Then hand crimp the first 12" of the seam using the Double Lock Hand Crimper (Fig. 2). Note: The Single Lock Hand Crimper MUST be used before the Double Lock Hand Crimper.
5. Crimp the side lap every four feet (4'-0") prior to seaming.

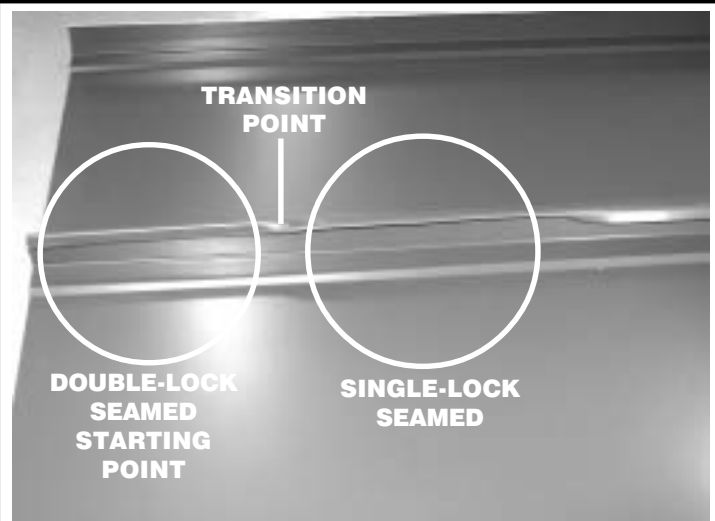

FIG. 3 - CLOSE-UP OF HAND-CRIMPED SEAM READY FOR MACHINE SEAMING.

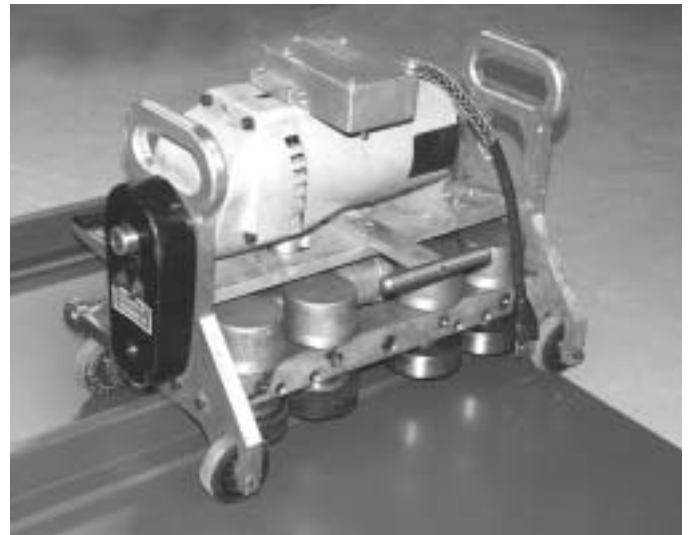

FIG. 4 - DOUBLE LOCK SEAMER ON PANEL AT STARTING POINT

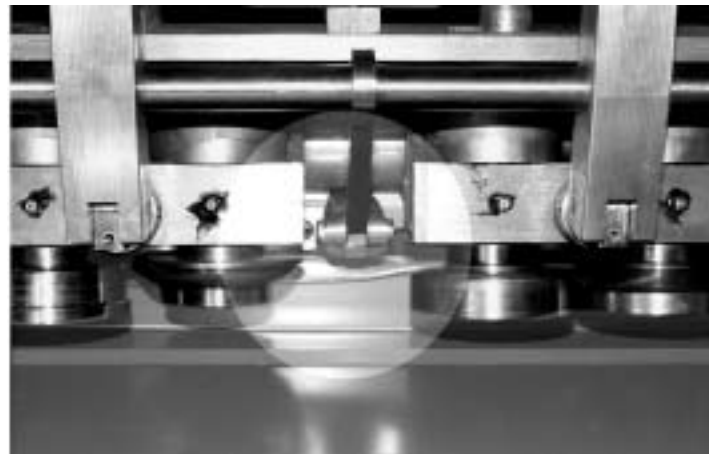

FIG. 5 - LIFT AND POSITION SEAMER AT THE STARTING POINT -- THE TRANSITION IN THE PANEL SEAM FROM DOUBLE-LOCK TO SINGLE LOCK SHOULD BE IN THE CENTER OF THE SEAMER.

## IV. MAINTENANCE INSTRUCTIONS

**THE BERRIDGE DOUBLE-LOCK ZEE-LOCK SEAMER** requires very little maintenance. To insure the highest quality product and maximum machine life, the following routine preventative maintenance is required. Keep the machine **DRY, CLEAN & DIRT-FREE**; this is a precision piece of equipment.

1. Inspect rollers prior to each usage. If necessary, remove any dirt, debris or remnants of strippable protective plastic film from rollers.
2. Clean all strippable film from drive and idler rollers at the completion of seaming and wipe with a clean cloth.

## V. SAFETY

It is important to abide by normal safety rules when operating the BERRIDGE DOUBLE-LOCK ZEE-LOCK SEAMER. While Berridge recommends the following minimum safety practices, the company accepts no responsibility for personal injury or property damage incurred while operating the machine.

- A. Make sure electrical outlet is grounded.
- B. Do not operate machine in rain or stand in water while operating.
- C. Make sure electrical cord is free of cuts and exposed wire.
- D. Keep hands and clothing away from the rollers.
- E. ***Do not allow seamer to travel off end of panel and over the edge of the building eave; Seamer does NOT automatically shut off at end of seam.***

### NOTE TO LESSEES:

**The Berridge Double-Lock Zee-Lock Seamer is shipped in good working condition and must be returned in the same condition. The cost of any required repairs for damage or deterioration caused by misuse or negligence will be charged to lessee.**

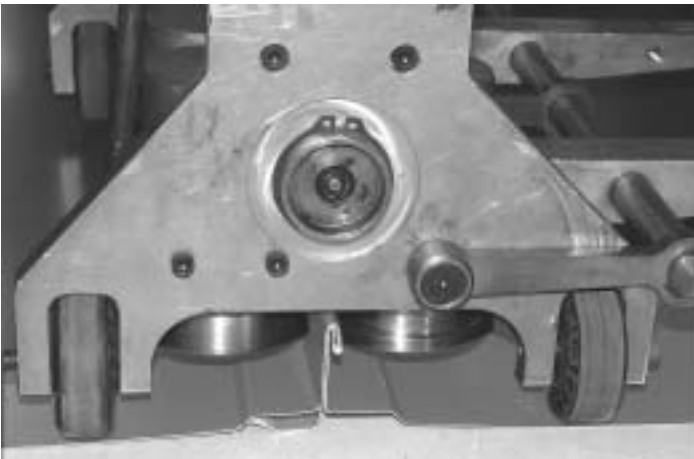

FIG. 6. - CLOSE-UP OF SEAMER ON PANEL SEAM (FROM TRAILING END OF SEAMER)

6. Hold the Motor Handle Grips firmly and open the dies with the Die Handle Lever. Once the dies are open, inspect die rollers for foreign objects such as pieces of strippable film which could interfere with seaming or mar paint finish.
7. Lift Seamer by Motor Grip Handles and position over side lap so that roller dies are correctly positioned over panel legs. (Fig. 5). The side of the Seamer with rubber forming rollers should be on the flat side of the seam. The transition in the panel seam from the Double Lock to the Single Lock (point where Double Lock Hand Crimper was stopped) should be in the **center** of the seamer.
8. Use the Die Lever Handle to close die rollers over the sidelap (see Fig. 5 for proper die positioning).
10. Turn the power switch on. After the seamer has travelled 18" to 24", turn the power switch off and check the seam for correct profile.  
**CAUTION: DO NOT LET THE SEAMER TRAVEL OFF THE END OF THE PANELS AND OVER THE EDGE OF THE EAVE; THE SEAMER DOES NOT AUTOMATICALLY SHUT OFF AT THE END OF THE SEAM.**
11. Hand seam terminating end of sidelap if obstruction prevents Seaming Machine from seaming sidelap all the way to the end.
11. Roof slopes with a rise of more than 6 inches in 12 inches should be seamed in a downhill direction. Attempting to run seamer uphill on steep slope roofs may cause roller dies to slip and rub paint off panel legs.
12. Roller dies should be inspected for strippable plastic film or other debris prior to operation, and cleaned periodically and at completion of seaming. **Remove ALL remnants of strippable plastic film.**



# **BERRIDGE DOUBLE-LOCK ZEE-LOCK SEAMER RETURN INFORMATION**

---

**DATE RETURNED** \_\_\_\_\_

**SERIAL #** \_\_\_\_\_

**COMMENTS:** \_\_\_\_\_

\_\_\_\_\_

\_\_\_\_\_

\_\_\_\_\_

**REPAIRS:** \_\_\_\_\_

\_\_\_\_\_

**LABOR COST:** \_\_\_\_\_

\_\_\_\_\_

**PARTS COST:** \_\_\_\_\_

\_\_\_\_\_

**FILL OUT & MAIL OR FAX TO:**

**BERRIDGE MANUFACTURING COMPANY  
ROLL FORMER OPERATIONS  
2201 Rudeloff Road  
Seguin, TX 78155  
Fax: 210-303-0530**



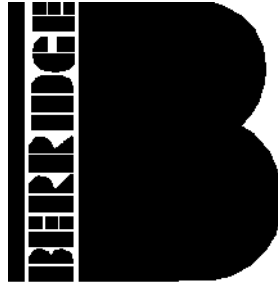

*Roofs of Distinction*

## **BERRIDGE MANUFACTURING COMPANY**

**1720 Maury Street, Houston, Texas 77026**

**(800) 231-8127**

**Fax: (713) 236-9422**

**www.berridge.com**

**for Roll Former Technical Assistance  
Call Seguin Branch toll-free: 1 (800) 303-0811  
Fax: (830)-303-0530**

### **SALES HQ**

**SAN ANTONIO, TX**  
6515 Fratt Rd  
San Antonio, TX 78218  
1-800-669-0009  
Fax: 210-650-0379

### **SALES & DISTRIBUTION BRANCH OFFICES**

**SEGUIN, TX**  
2201 Rudeloff Rd  
Seguin, TX 78155  
1-800-303-0811  
Fax: 830-303-0530

**DENVER, CO**  
7801 E. 40th St.  
Denver, CO 80207  
1-800-735-3703  
Fax: 303-322-3810

**CHICAGO, IL**  
1175 Carolina Dr.  
W. Chicago, IL 60185  
1-800-488-7415  
Fax: 630-231-7520

**ATLANTA, GA**  
319 Lee Industrial Blvd  
Austell, GA 30168  
1-800-927-9712  
Fax: 770-941-7344