

BERMUDA PANEL INSTALLATION DETAILS

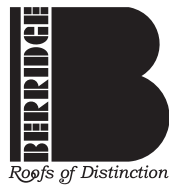
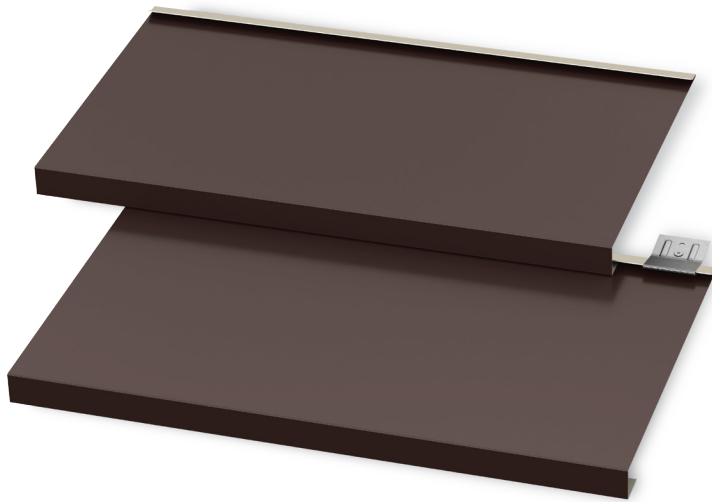

**BERRIDGE
MANUFACTURING
COMPANY**

800-669-0009 • www.Berridge.com

| | |
|--|-------|
| INDEX | BP-1 |
| INDEX | BP-2 |
| INSTALLATION INSTRUCTIONS | BPI-1 |
| INSTALLATION INSTRUCTIONS | BPI-2 |
| INSTALLATION INSTRUCTIONS | BPI-3 |
| INSTALLATION INSTRUCTIONS | BPI-4 |
| NOMINAL LINEAR EXPANSION | BPI-5 |
| INTRODUCTION TO TYPICAL DETAILS | BP-4 |
| OVERVIEW BP PANEL | BP-5 |
| SPLICE PLATE DETAIL (SOLID SHEATHING) | BP-6 |
| SPLICE PLATE DETAIL (OPEN FRAMING) | BP-7 |
| EAVE DETAIL; | BP-10 |
| EAVE DETAIL; | BP-11 |
| RIDGE DETAIL; (SOLID SHEATHING) | BP-20 |
| RIDGE DETAIL; (OPEN FRAMING) | BP-21 |
| RIDGE DETAIL; (SOLID SUBRATE) | BP-22 |
| SHED RIDGE DETAIL | BP-23 |
| RIDGE DETAIL; (SOLID SHEATHING) | BP-24 |
| RIDGE DETAIL; (OPEN FRAMING) | BP-25 |
| RIDGE TERMINATION AT DORMER VALLEY | BP-26 |
| GABLE DETAIL; (SOLID SUBSTRATE) | BP-30 |
| GABLE DETAIL; (OPEN FRAMING) | BP-31 |
| HEAD WALL; | BP-40 |
| HEAD WALL; (OPEN FRAMING) | BP-41 |
| HEAD WALL; (SOLID SUBSTRATE) | BP-42 |
| HEAD WALL; WITH PARAPET | BP-43 |
| RAKE WALL; (SOLID SUBSTRATE) | BP-50 |
| RAKE WALL; (SOLID SUBSTRATE) | BP-51 |
| RAKE WALL; (OPEN FRAMING) | BP-52 |
| RAKE WALL; STEP FLASHING (SOLID SHEATHING) | BP-53 |
| SLOPE TRANSITION WITH FLASHING | BP-60 |



**BERRIDGE
MANUFACTURING
COMPANY**

INDEX

Bermuda Panel System

DATE: 08-15-06

PAGE/FILE
BP-1

| | |
|---|-------|
| VALLEY | BP-70 |
| VALLEY; | BP-71 |
| VALLEY | BP-72 |
| VALLEY; ISOMETRIC | BP-73 |
| VALLEY; OPEN FRAMING | BP-74 |
| | |
| ROOF PENETRATION; PIPE PENETRATION | BP-80 |
| ROOF PENETRATION; SQUARE (PLAN VIEW) | BP-81 |
| ROOF PENETRATION; SECTION A | BP-82 |
| ROOF PENETRATION; SECTION B | BP-83 |
| ROOF PENETRATION; OPEN FRAMING | BP-84 |
| | |
| U.L. 90 CONST. NO. 405 (SOLID WOOD SHEATHING) | BP-90 |



**BERRIDGE
MANUFACTURING
COMPANY**

INDEX

DATE: 08-15-06

Bermuda Panel System

PAGE/FILE
BP-2

A. BERMUDA PANEL SYSTEM: CAN BE FACTORY OR FIELD FABRICATED USING A PORTABLE ROLL FORMER. PANELS ARE FORMED TO A CONSTANT EXPOSURE WIDTH OF 11" AND A PANEL DEPTH OF 1".

B. MINIMUM SLOPE: PANELS ARE RECOMMENDED FOR ROOF SLOPES OF 3 IN 12 OR GREATER. A DOUBLE LAYER OF 30# FELT UNDERLAYMENT IS RECOMMENDED FOR 3 IN 12 SLOPES.

C. MATERIAL STORAGE: CAUTION MUST BE EXERCISED IN STORAGE OF MATERIALS PRIOR TO INSTALLATION. KEEP ALL BERRIDGE PREFINISHED MATERIAL IN A DRY LOCATION WITH ADEQUATE VENTILATION AND OUT OF DIRECT SUNLIGHT.

EXPOSURE TO DIRECT SUNLIGHT AND/OR MOISTURE MAY CAUSE THE FACTORY APPLIED STRIPPABLE PLASTIC FILM TO ADHERE TO THE METAL PERMANENTLY AND DISCOLOR THE FINISH.

D. STRIPPABLE FILM: THE STRIPPABLE PLASTIC FILM WHICH IS APPLIED OVER MOST BERRIDGE PREFINISHED PRODUCTS, PANELS, FLASHINGS, COILS AND FLAT SHEETS PROTECTS THE FINISH DURING FABRICATION AND TRANSIT. THIS FILM MUST BE REMOVED PRIOR TO INSTALLATION.

E. SOLID SHEATHING REQUIREMENTS: BERRIDGE MANUFACTURING COMPANY RECOMMENDS THE USES OF EITHER BERRIDGE 24 GA. CORRUGATED METAL (NOMINAL 2-1/2" PITCH x 11/16" DEPTH) OR A MINIMUM OF 1/2" PLYWOOD SHEATHING TO PROVIDE SUFFICIENT HOLDING POWER FOR FASTENERS. CONTACT BERRIDGE MANUFACTURING'S ENGINEERING DEPARTMENT FOR USE OF ANY OTHER TYPE OF SOLID SHEATHING. (30 # FELT UNDERLAYMENT OR EQUAL MUST BE USED OVER ANY SOLID SHEATHING).

DUE TO # 30 FELTS TENDENCY TO TEAR WHEN USED OVER CORRUGATED DECKING, BERRIDGE MANUFACTURING RECOMMENDS GRACE ICE AND WATERSHIELD OR EQUAL TO BE USED AS AN UNDERLAYMENT FOR ALL CORRUGATED DECKS.

NOTE: FOR PROJECTS REQUIRING UL 90 ASSEMBLY, REFER TO UL 90 DETAILS.

F. SHEATHING INSPECTION:

1. SHEATHING END JOINTS SHOULD BE STAGGERED.
2. ALL END JOINTS SHOULD MEET AT EITHER A JOIST OR RAFTER.
3. BLOCKING OR "H" CLIPS SHOULD BE USED ON PLYWOOD IF JOINTS DO NOT REMAIN FLAT UNDER THE WEIGHT OF WORKMEN.
4. USE SHIMS TO KEEP ENTIRE SUBSTRATE EVEN. UNEVEN SUBSTRATE WILL RESULT IN "OIL-CANNING" IN PANELS. SUBSTRATE SHOULD BE LEVEL TO 1/4" IN 20'-0".
5. ALL CUTS AT PENETRATIONS SHOULD BE TIGHT, WITHOUT GAPS.
6. USE WOOD FRAMED CRICKETS AT LARGE PENETRATIONS.
7. MAKE SURE SUBSTRATE JOINTS ARE TIGHT AT ALL HIPS, VALLEYS AND RIDGES.

G. INSTALLATION OVER OPEN FRAMING;

DIAPHRAGM CAPABILITIES AND PURLIN STABILITY ARE MINIMAL AS PROVIDED BY THE BERMUDA PANEL SYSTEM, THEREFORE OTHER BRACING MAY BE REQUIRED TO CONFORM TO A.I.S.C. OR A.I.S.I. SPECIFICATIONS.



**BERRIDGE
MANUFACTURING
COMPANY**

INSTALLATION INSTRUCTIONS

Bermuda Panel System

DATE: 08-15-06

PAGE/FILE
BPI-1

H. OPEN FRAMING INSPECTION:

1. PURLINS SHOULD BE ALIGNED WITH TOP FLANGES IN THE SAME PLANE TO A TOLERANCE OF 1/4" IN 20'-0". UNEVENNESS IN THE TOP PLANE OF THE PURLINS WILL RESULT IN ABNORMAL "OIL CANNING" OF PANELS. PURLINS SHALL BE ADEQUATELY BRACED.
2. BERRIDGE MANUFACTURING COMPANY REQUIRES SOLID SHEATHING IN VALLEY AND AROUND ROOF PENETRATIONS. DO NOT APPLY PANELS ON OPEN FRAMING AT VALLEYS OR ROOF PENETRATIONS WITHOUT REFERRING TO DETAILS
3. FOOT TRAFFIC ON THE PANELS MUST BE KEPT TO A MINIMUM. ARCHITECTURAL PANELS ARE DESIGNED FOR AESTHETICS AND CAN BE EASILY DAMAGED OR DEFORMED IF EXTREME CARE IS NOT USED.

I. FASCIA/RAKE INSPECTION:

1. STRIKE A LINE THE FULL LENGTH OF THE FASCIA OR RAKE. IF NOT STRAIGHT, CORRECT WITH SHIMS.
2. MAKE SURE FASCIA/RAKE IS FLUSH WITH SHEATHING.

J. FELT UNDERLAYMENT: A SINGLE LAYER OF NUMBER THIRTY FELT UNDERLAYMENT (OR EQUAL) MUST BE APPLIED OVER SOLID SHEATHING AS SHOWN IN THE BERRIDGE MANUFACTURING COMPANY TYPICAL UNDERLAYMENT DETAILS. THE USE OF ADDITIONAL LAYERS OF NUMBER THIRTY FELT IS RECOMMENDED ON LOW-SLOPED ROOFS, AT ALL VALLEY CONDITIONS, AT ROOF PENETRATIONS, AND CERTAIN OTHER FLASHING CONDITIONS AS DEPICTED IN THE BERRIDGE TYPICAL UNDERLAYMENT DETAILS. GRACE ICE AND WATER SHIELD MAY BE REQUIRED ON LOW SLOPED ROOFS OR AT CERTAIN FLASHING CONDITIONS.

K. FELTING INSTALLATION:

1. DO NOT USE RED ROSIN PAPER UNDER METAL ROOFING PANELS.
2. SWEEP ROOF AREA CLEAN.
3. USE FLAT HEAD GALVANIZED ROOFING NAILS x 1-1/4" LONG WITH BERRIDGE GALVANIZED FELT CAPS.
4. INSTALL VALLEY FELT FIRST.
5. INSTALL FELT PARALLEL TO EAVE (2 LAYERS REQUIRED AT EAVE), STARTING AT EAVE AND USING MINIMUM 6" LAPS. USE TWO LAYERS OF FELT ON ENTIRE ROOF DECK IF ROOF SLOPE IS 3:12 OR LESS. 2 LAYERS REQUIRED AT EAVE REGARDLESS OF SLOPE.
6. INSULATE BETWEEN WOOD BLOCKING AND METAL WITH FELT OR ICE AND WATER SHIELD.
7. REFER TO UNDERLAYMENT DETAILS. WHEN VALLEYS OR ROOF PENETRATIONS ARE INVOLVED ON OPEN FRAMING CONDITIONS.

L. THERMAL MOVEMENT: EXPANSION AND CONTRACTION OF PANELS WHICH EXCEED THIRTY FEET IN LENGTH CAN BE A FACTOR IN THE DESIGN AND INSTALLATION OF FLASHING AND PANELS. PLEASE REFER TO THE CHART ON PAGE BPI-5 TO DETERMINE ANTICIPATED THERMAL MOVEMENT OF THE PANELS. IMPROPERLY DESIGNED FLASHING CAN ALLOW PANELS TO DISENGAGE FROM THE FLASHING, ALLOW OIL-CANNING IN PANEL AND/OR CAUSE FLASHING TO WORK LOOSE FROM ITS ANCHORAGE.

1. PANELS OVER 30'-0" LONG REQUIRE EXPANSION JOINTS SEE DETAIL BP-6 AND BP-7.



**BERRIDGE
MANUFACTURING
COMPANY**

**INSTALLATION
INSTRUCTIONS**

Bermuda Panel System

DATE: 08-15-06

PAGE/FILE
BPI-2

M. ELECTROLYSIS: AVOID ALLOWING FLASHING AND PANELS TO COME INTO CONTACT WITH EITHER LEAD OR COPPER, AND PREVENT EXPOSURE TO WATER RUNDOWN FROM COPPER AND/OR LEAD.

N. FLASHING: IF BERRIDGE MANUFACTURING COMPANY IS TO SUPPLY FLASHING, ALL FLASHINGS WILL BE FABRICATED IN 10'-0" LENGTHS WITH SQUARE END CUTS ONLY. THE PURCHASER MUST PROVIDE ALL DIMENSIONS AND DEGREE OF ANGLES.

1. REMOVE STRIPPABLE PLASTIC FILM FROM ALL FLASHINGS PRIOR TO INSTALLATION.
2. ALWAYS STAGGER JOINTS WHEN ONE FLASHING IS INSTALLED OVER OTHER FLASHINGS.
3. INSTALL ALL FLASHINGS AS PER BERRIDGE TYPICAL DETAILS.
4. ALL FLASHINGS ARE TO BE DESIGNED AND INSTALLED TO NOT TRAP WATER.

O. SEALENT RECOMMENDATIONS: TREMCO, INC. "SPECTREM 1" SILICONE SEALANT.

P. PANELS: BERRIDGE MANUFACTURING COMPANY WILL PROVIDE SQUARE END CUTS ONLY ON ALL BERMUDA PANELS. COMPUTATION OF ALL QUANTITIES AND DIMENSIONS ARE THE RESPONSIBILITY OF THE PURCHASER.

Q. PANEL INSTALLATION:

1. INSTALL STARTER STRIP CONTINUOUS AT EAVE.
2. REMOVE STRIPPABLE PLASTIC FILM FROM EACH PANEL PRIOR TO INSTALLATION.
3. START AT EAVE WITH PANEL AND WORK TOWARD THE RIDGE. PANEL END CUTS NEED TO BE ACCURATE WHEN USING THE VINYLWEATHERSEAL.
4. KEEP PANELS ALIGNED SO THAT PANELS MATCH AT HIPS AND VALLEYS. **DO NOT** INSTALL LONG CONTINUOUS RUNS OF PANELS ALL AT ONE TIME WHERE PANEL LINES MUST MATCH. INSTALL TEN TO TWELVE PANELS IN ONE ELEVATION AND THEN FOLLOW WITH A LIKE NUMBER OF PANELS ON THE OTHER ELEVATION. WHEN YOU INSTALL PANELS IN THIS MANNER, YOU WILL BE ABLE TO MAKE ANY ADJUSTMENTS REQUIRED TO INSURE PANEL MATCHING.
5. INSTALL CLIPS AS PER CLIP INSTALLATION NOTES.
6. EACH PANEL IS TO BE KEPT TIGHT AGAINST THE ADJOINING PANEL. NEVER PERMIT A GAP BETWEEN THE MALE/FEMALE JOINT ANY CRIMPS IN MALE LEG **MUST** BE STRAIGHTENED (TOTALLY STRAIGHT WITH OUT ANY BENDS, CRIMPS, CREASES, ETC.) PRIOR TO PANEL INSTALLATION.
7. COPPER-COTE,[™] CHAMPAGNE, LEAD-COTE,[™] AND PREWEATHERED GALVALUME[®] PANEL INSTALLATION: NOTE THE SERIES OF ARROWS PAINTED ON THE UNDERSIDE OF THE PANEL. ALL PANELS MUST BE INSTALLED IN A CONSISTENT MANNER, MEANING THAT THE ARROWS ON EVERY PANEL ARE ALL POINTING IN THE SAME DIRECTION. IF A PANEL IS REVERSED (ARROWS POINTING OPPOSITE OF THOSE ON OTHER PANELS) IT WILL APPEAR, FROM A DISTANCE, A DIFFERENT SHADE DUE TO THE GRANULAR EFFECT OF THE PIGMENTS IN THE FINISH. METALLIC FINISHES ARE MATCH - LOT FINISHES. DO NOT MIX LOTS.



**BERRIDGE
MANUFACTURING
COMPANY**

INSTALLATION INSTRUCTIONS

Bermuda Panel System

DATE: 08-15-06

PAGE/FILE
BPI-3

R. CLIP INSTALLATION:

1. INSTALL CLIPS AS PER DETAILS.
2. CLIP SPACING ON SOLID SHEATHING NOT TO EXCEED 20" ON CENTER.*
3. WHEN INSTALLING PANEL OVER OPEN FRAMING, USE CLIPS ALONG EVERY PURLIN AT 20" ON CENTER MAXIMUM.*

* NOTE: IF LOCAL CODES OR OTHER REGULATIONS DICTATE SPECIFIC WIND UPLIFT REQUIREMENTS, CONSULT THE BERRIDGE ENGINEERING DEPARTMENT, AS IT MAY BE NECESSARY TO USE A DIFFERENT CLIP SPACING OR FASTENER.

S. FASTENERS: INSTALL FASTENERS AS PER TYPICAL DETAILS. USE 11 GAUGE 1-1/4" GALVANIZED ROOFING NAILS FOR INSTALLATION OVER WOOD SHEATHING AND USE #10 PANCAKE HEAD TEKS FASTENERS (ZINC-PLATED SCREW WITH PHILLIPS INSERT, AS MADE BY CONSTRUCTION FASTENERS CO.) FOR INSTALLATION TO METAL.** WHEN USING POP RIVETS ON FLASHING, STAINLESS STEEL RIVETS ARE RECOMMENDED TO AVOID RUST RUST STAINS.

MAKE SURE ALL FASTENERS ARE DRIVEN STRAIGHT AND SET FLAT. DO NOT OVERDRIVE FASTENERS, AS THIS WILL CAUSE THE CLIP AND/OR FLASHINGS TO BUCKLE OR BECOME RECESSED BELOW THE ELEVATION OF THE SUBSTRATE.

** NOTE: CONSULT BERRIDGE MANUFACTURING'S ENGINEERING DEPARTMENT REGARDING THE USE OF ANY OTHER TYPE OF FASTENER.

BERRIDGE MANUFACTURING COMPANY STRIVES TO PROVIDE ITS CUSTOMERS WITH THE HIGHEST QUALITY STRETCHER LEVELED STEEL AVAILABLE. THE LATEST TECHNOLOGY IS ALSO INCORPORATED IN BERRIDGE'S HIGH-PRECISION COIL HANDLING AND ROLL FORMING EQUIPMENT TO MINIMIZE THE STRESS ON METAL DURING PRODUCTION. FURTHERMORE, BERRIDGE UTILIZES HEAVIER 24 GAUGE METAL RATHER THAN 26 GAUGE STEEL OR LIGHT GAUGE ALUMINUM AS OFFERED BY MANY COMPETITORS. ALL THESE MEASURES HAVE BEEN TAKEN TO MINIMIZE THE AMOUNT OF "OIL-CANNING" (WAVINESS) WHICH IS NATURALLY INHERENT IN FLAT SHEET METAL. MANY TIMES, HOWEVER, THE CAUSE OF WAVINESS OR "OIL-CANNING" CAN BE TRACED TO UNEVEN SHEATHING, IMPROPER FELT INSTALLATION, IMPROPER HANDLING, OR FOOT TRAFFIC ON THE PANELS.

ALL ARCHITECTURAL PANELS REQUIRE CARE IN HANDLING AND INSTALLATION TO AVOID DAMAGING OR DEFORMING THE PANELS.

THESE INSTALLATION INSTRUCTIONS AND THE FOLLOWING TYPICAL DETAILS ARE INTENDED TO PROVIDE OUR CUSTOMERS WITH THE INFORMATION REQUIRED FOR AN AESTHETICALLY PLEASING AND FUNCTIONAL INSTALLATION OF THE BERRIDGE BERMUDA PANEL SYSTEM.

NOTE: ALL PRODUCTS, SPECIFICATIONS, DETAILS, AND INSTRUCTIONS SUBJECT TO CHANGE WITHOUT NOTICE. FOR SPECIFIC PROJECT DETAILS, CONTACT BERRIDGE.



**BERRIDGE
MANUFACTURING
COMPANY**

INSTALLATION INSTRUCTIONS

Bermuda Panel System

DATE: 08-15-06

PAGE/FILE
BPI-4

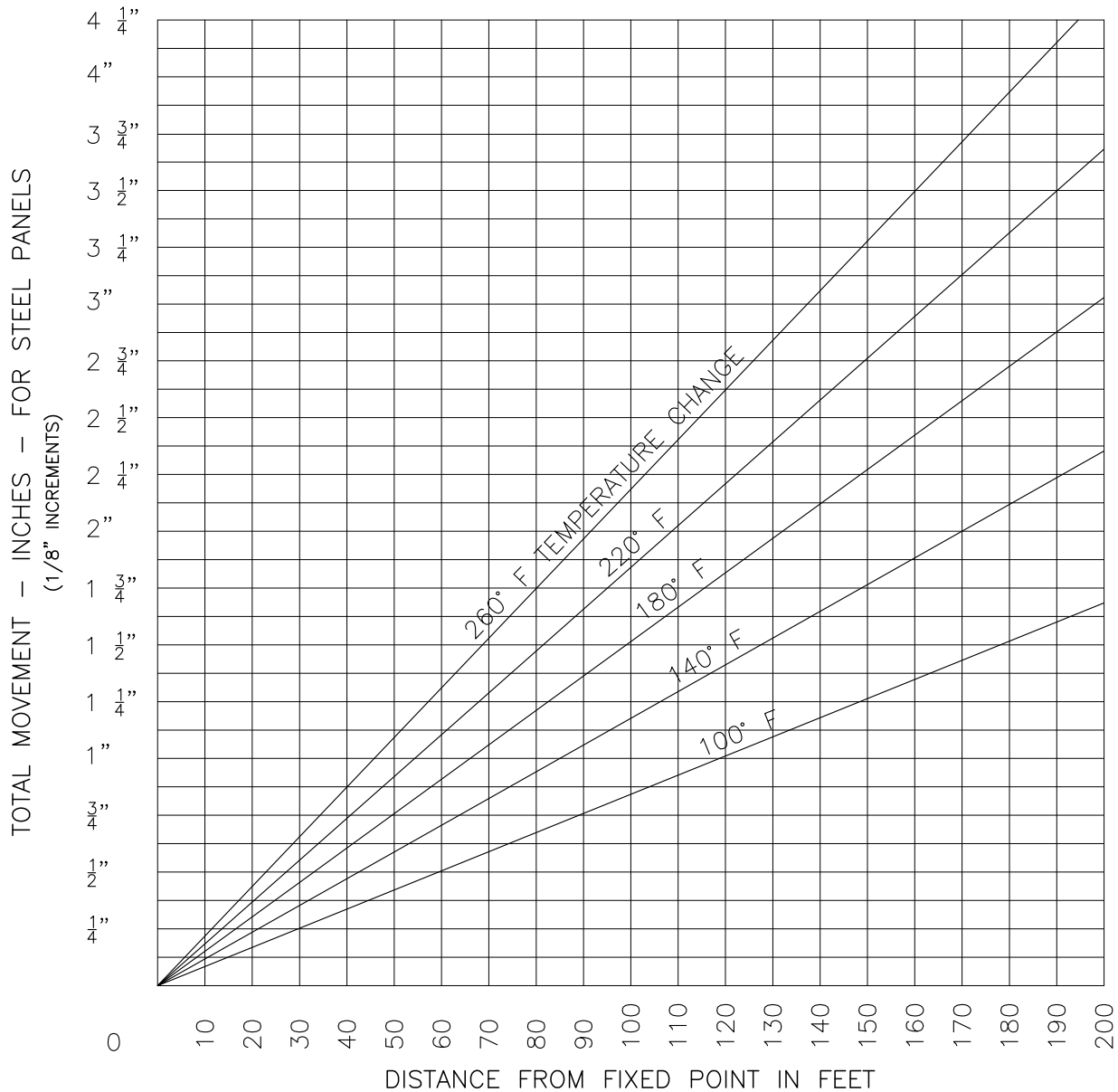

EXPANSION AND CONTRACTION OF METAL PANELS DUE TO LONGITUDINAL THERMAL MOVEMENT MUST BE CONSIDERED IN BOTH DESIGN AND INSTALLATION. THE ABOVE CHART EMPHASIZES THE NEED TO PROVIDE AMPLE CLEARANCES FROM GUTTERS, RIDGES, ENDWALL, ETC.

MAXIMUM TEMPERATURE SHOULD BE NO LOWER THAN 140°F FOR WHITE PANELS, UP TO 180° FOR DARK PAINTED PANELS, REGARDLESS OF AMBIENT MAXIMUM, MINIMUM SHOULD BE FIGURED WELL BELOW AMBIENT MINIMUM TO ALLOW FOR RADIATION TO NIGHT SKY. IN ANY CASE, A MINIMUM OF 100°F DIFFERENTIAL IS RECOMMENDED.



**BERRIDGE
MANUFACTURING
COMPANY**

Roofs of Distinction

INSTALLATION INSTRUCTIONS

Bermuda Panel System

DATE: 10-30-17

PAGE/FILE
BPI-5

THE DETAILS CONTAINED IN THE FOLLOWING PAGES ARE MERELY RECOMMENDATIONS AS TO HOW BERRIDGE MANUFACTURING MATERIALS SHOULD BE INSTALLED. THEY MAY REQUIRE ADAPTATIONS OR MODIFICATIONS FOR A SPECIFIC PROJECT AS CONDITIONS VARY IN BOTH BUILDING DESIGN AND LOCAL WEATHER PECULIARITIES.

BERRIDGE MANUFACTURING COMPANY SHALL BE HELD HARMLESS FROM ANY AND ALL CLAIMS ARISING FROM LACK OF WATERTIGHTNESS AS A RESULT OF FOLLOWING THESE RECOMMENDED DETAILS. ENSURING WATERTIGHTNESS ON ANY GIVEN PROJECT IS THE FUNCTION OF THE INSTALLER. THE ARCHITECT/GENERAL CONTRACTOR/INSTALLER MUST ACCEPT THE RESPONSIBILITY TO ADAPT THESE DETAILS TO MEET PARTICULAR BUILDING REQUIREMENTS AND TO ASSURE ADEQUATE WATERTIGHTNESS.

THE INSTALLER CAN VIRTUALLY ASSURE WATERTIGHTNESS IF THESE FLASHING DETAILS HAVE BEEN PROPERLY ADAPTED, ADEQUATE LAPS HAVE BEEN PROVIDED, CORRECT TYPE OF SEALANT USED, ALL JOINTS ADEQUATELY CAULKED, AND PROFESSIONAL WORKMANSHIP EMPLOYED.



**BERRIDGE
MANUFACTURING
COMPANY**

INTRODUCTION TO TYPICAL DETAILS

Bermuda Panel System

DATE: 08-15-06

PAGE/FILE
BP-4

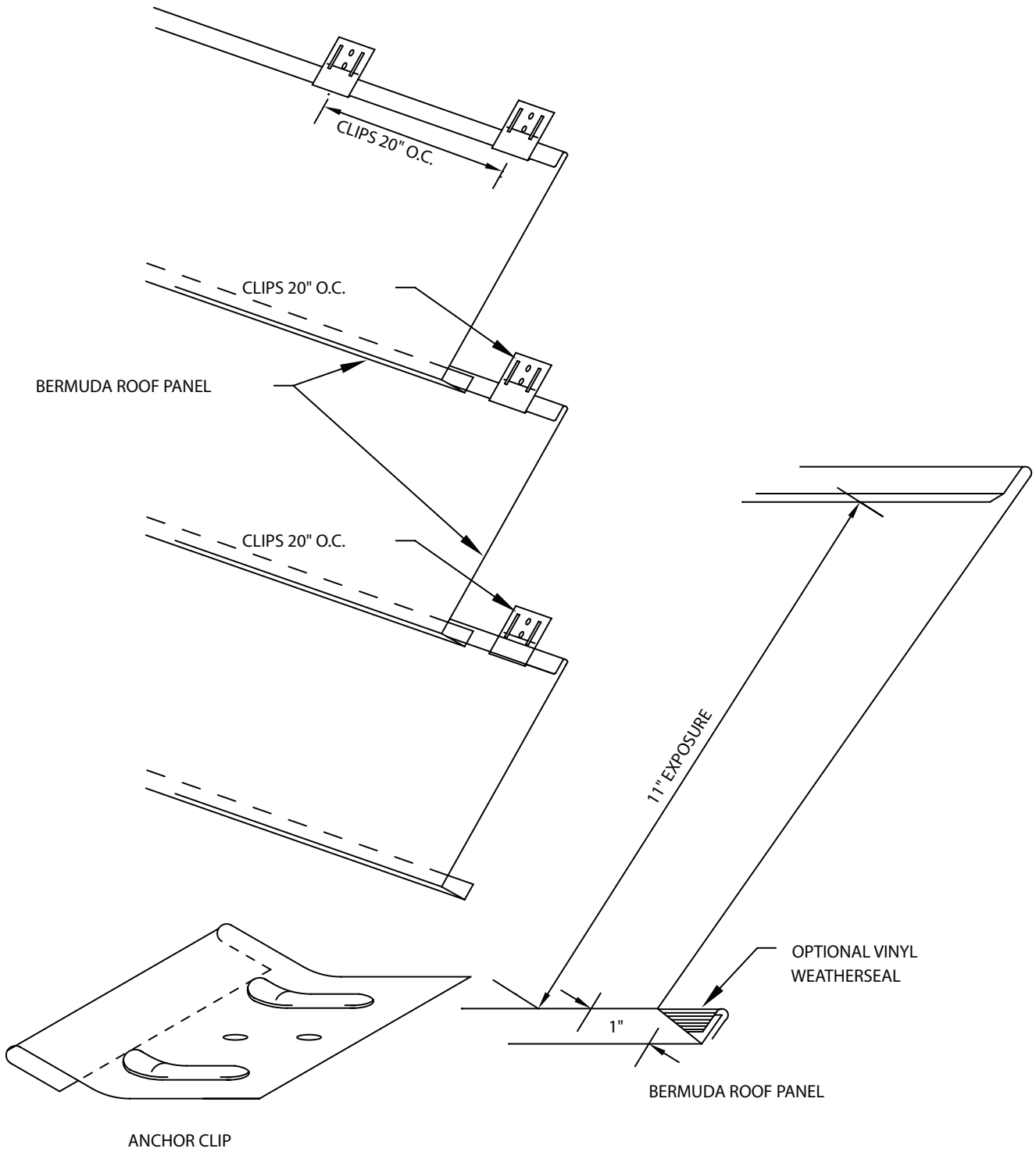

**BERRIDGE
MANUFACTURING
COMPANY**

PANEL OVERVIEW

Bermuda Panel System

DATE: 08-15-06

PAGE/FILE
BP-5

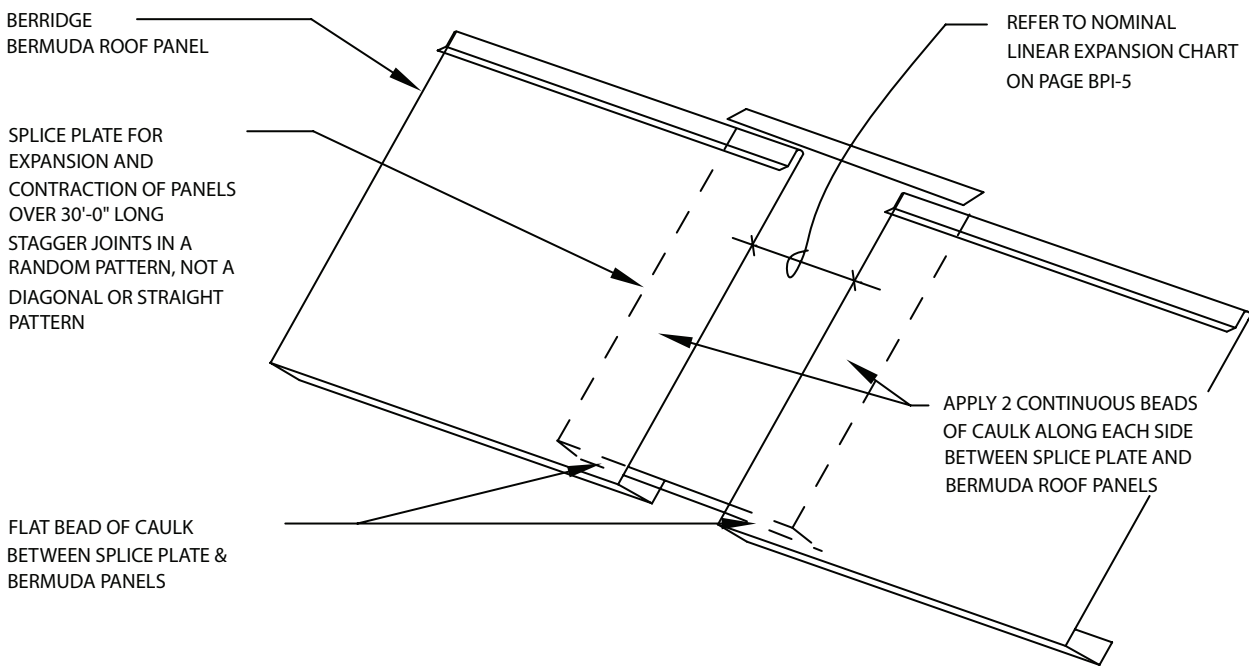
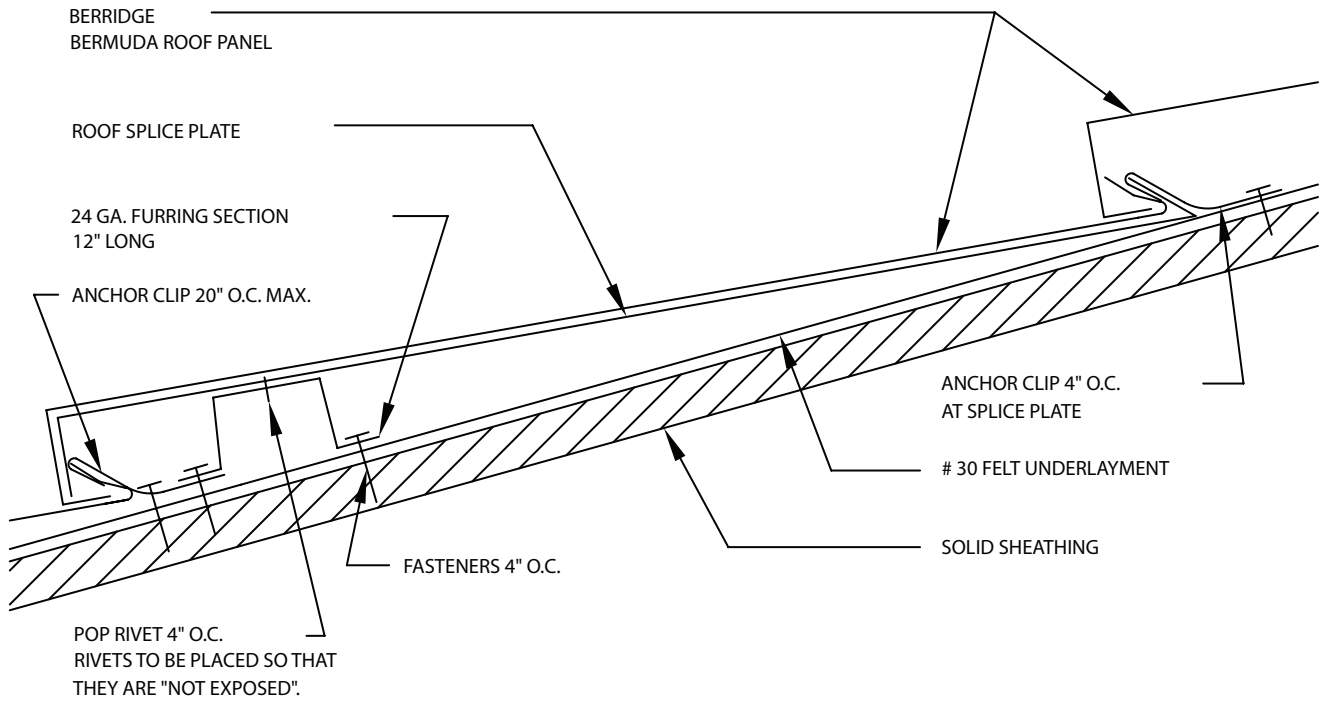

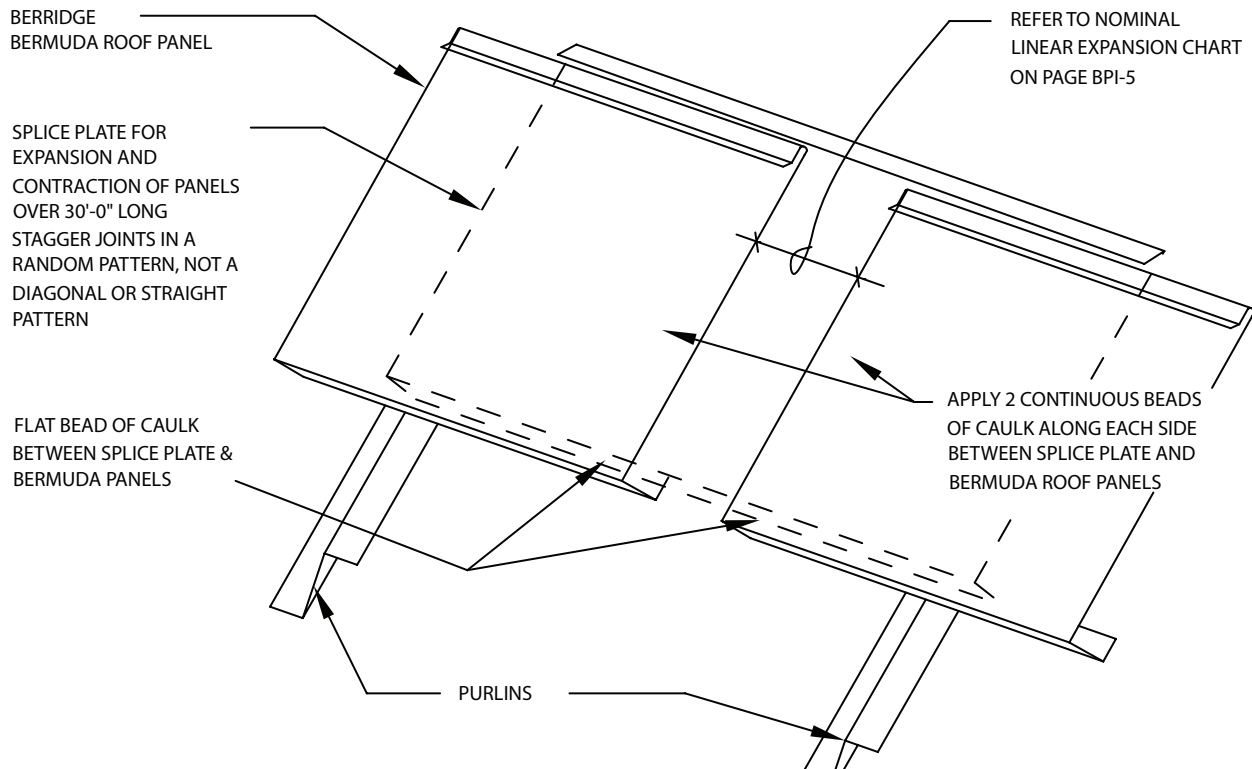
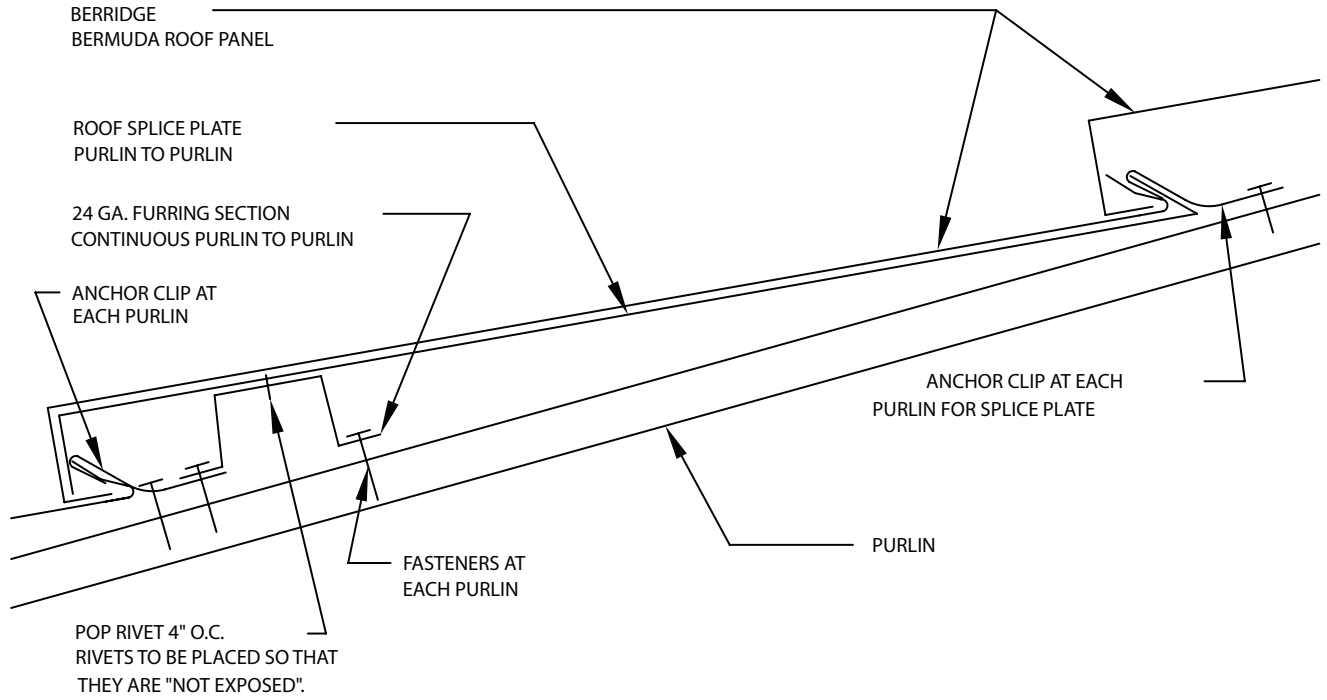

**BERRIDGE
MANUFACTURING
COMPANY**

SPLICE PLATE DETAIL OPEN FRAMING

Bermuda Panel System

DATE: 08-15-06

PAGE/FILE
BP-7

BERRIDGE BERMUDA PANEL

CONTINUOUS STARTER STRIP
ALIGN WITH EAVE FLASHING

EAVE FLASHING 4" END
LAPS WITH CONTINUOUS
CAULK AT LAPS

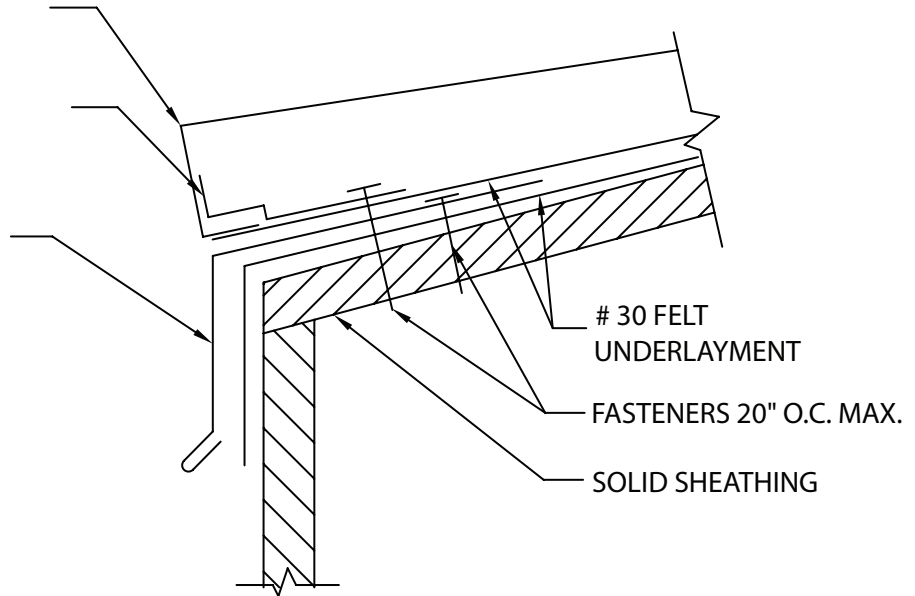

1. SOLID SHEATHING (BY OTHERS) TO BE MINIMUM 1/2" PLYWOOD OR EQUIVALENT IN STRENGTH FOR HOLDING POWER OF FASTENERS.
2. ALL FELT UNDERLAYMENT, CAULKING AND FASTENERS ARE ITEMS TO BE FURNISHED AND INSTALLED BY THE ROOFING INSTALLER AT THE DISCRETION OF THE ARCHITECT.

F = FINISH SIDE

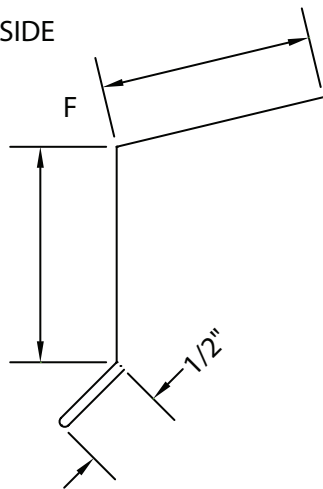

EAVE FLASHING

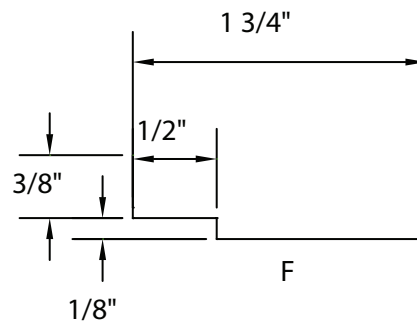

STARTER STRIP



**BERRIDGE
MANUFACTURING
COMPANY**

EAVE DETAIL

Bermuda Panel System

DATE: 08-15-06

PAGE/FILE

BP-10

BERRIDGE BERMUDA PANEL

CONTINUOUS STARTER STRIP
ALIGN WITH EAVE FLASHING

EAVE FLASHING 4" END
LAPS WITH CONTINUOUS
CAULK AT LAPS

BERRIDGE WALL PANEL OR
FASCIA PANEL

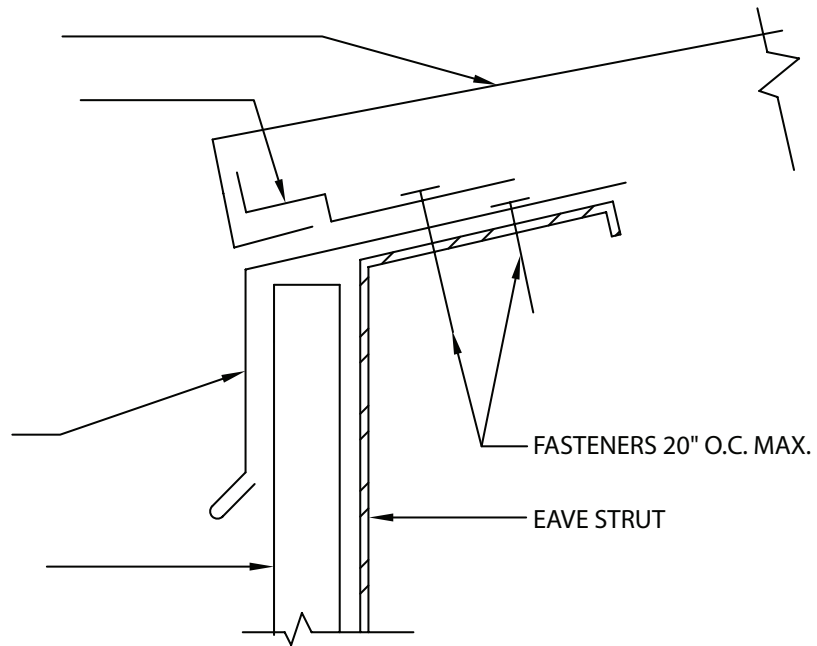

1. ALL CAULKING AND FASTENERS ARE ITEMS TO BE FURNISHED AND INSTALLED BY THE ROOFING INSTALLER AT THE DISCRETION OF THE ARCHITECT.

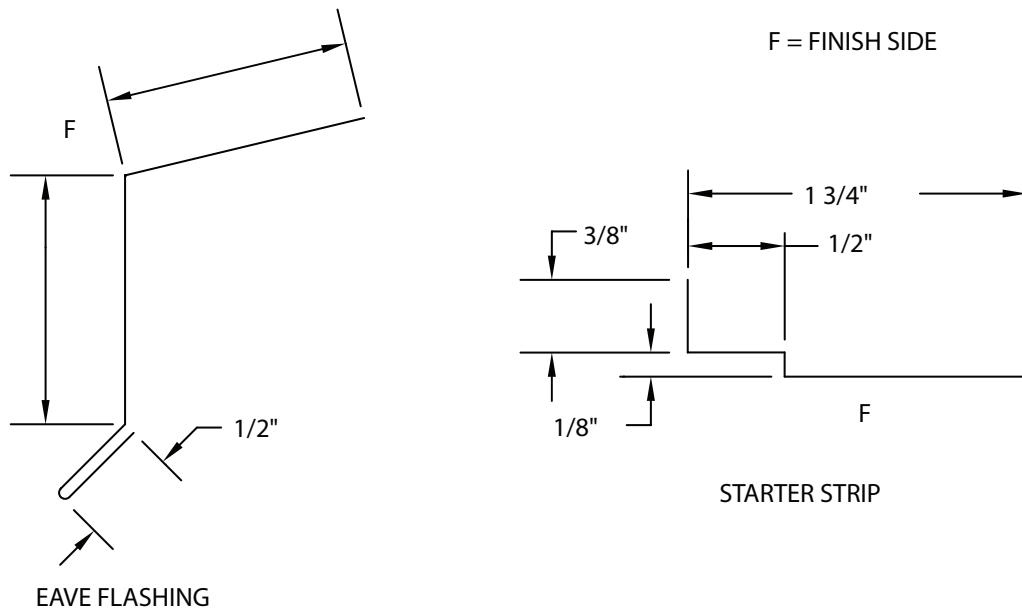

BERRIDGE
MANUFACTURING
COMPANY

Roofs of Distinction

EAVE DETAIL

Bermuda Panel System

DATE: 08-15-06

PAGE/FILE
BP-11

BERRIDGE BERMUDA PANEL

RIDGE FLASHING 4" END LAPS WITH CONTINUOUS CAULK AT LAPS, POP RIVET TO ZEE CLOSURE 40" O.C., AND AT LAPS. CAULK RIVET HEADS

ZEE CLOSURE 4" END LAPS WITH CONTINUOUS CAULK AT LAPS

SOLID SHEATHING

FASTENER 20" O.C. MAX.

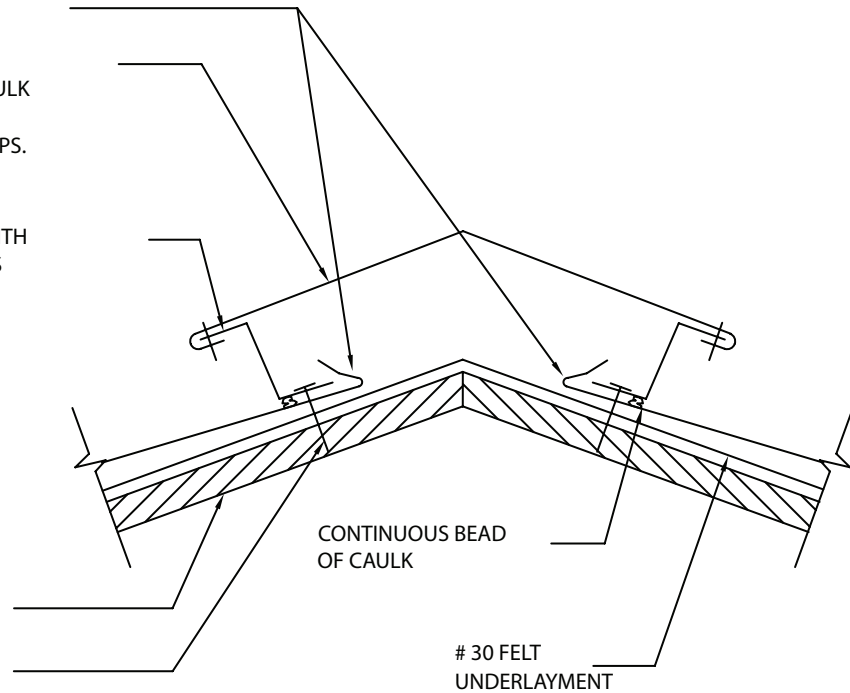

1. SOLID SHEATHING (BY OTHERS) TO BE MINIMUM 1/2" PLYWOOD OR EQUIVALENT IN STRENGTH FOR HOLDING POWER OF FASTENERS.

2. ALL FELT UNDERLAYMENT, CAULKING AND FASTENERS ARE ITEMS TO BE FURNISHED AND INSTALLED BY THE ROOFING INSTALLER AT THE DISCRETION OF THE ARCHITECT.

F = FINISH SIDE

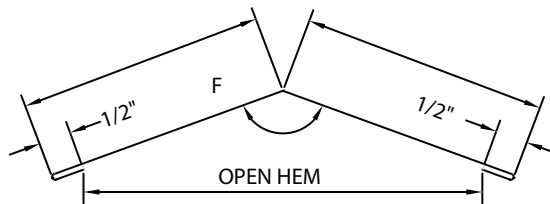

RIDGE FLASHING

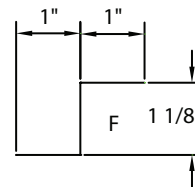

ZEE CLOSURE



BERRIDGE
MANUFACTURING
COMPANY

RIDGE DETAIL SOLID SHEATHING

Bermuda Panel System

DATE: 08-15-06

PAGE/FILE

BP-20

BERRIDGE BERMUDA PANEL
 RIDGE FLASHING 4" END
 LAPS WITH CONTINUOUS CAULK
 AT LAPS, POP RIVET TO ZEE
 CLOSURE 40" O.C., AND AT LAPS.
 CAULK RIVET HEADS

ZEE CLOSURE 4" END LAPS WITH
 CONTINUOUS CAULK AT LAPS

FASTENERS AT
 EVERY PURLIN

PURLINS

FASTENER 20"
 O.C. MAX.

CONTINUOUS BEAD
 OF CAULK

SUB FLASHING 4"
 END LAPS WITH
 CONTINUOUS
 CAULK AT LAPS

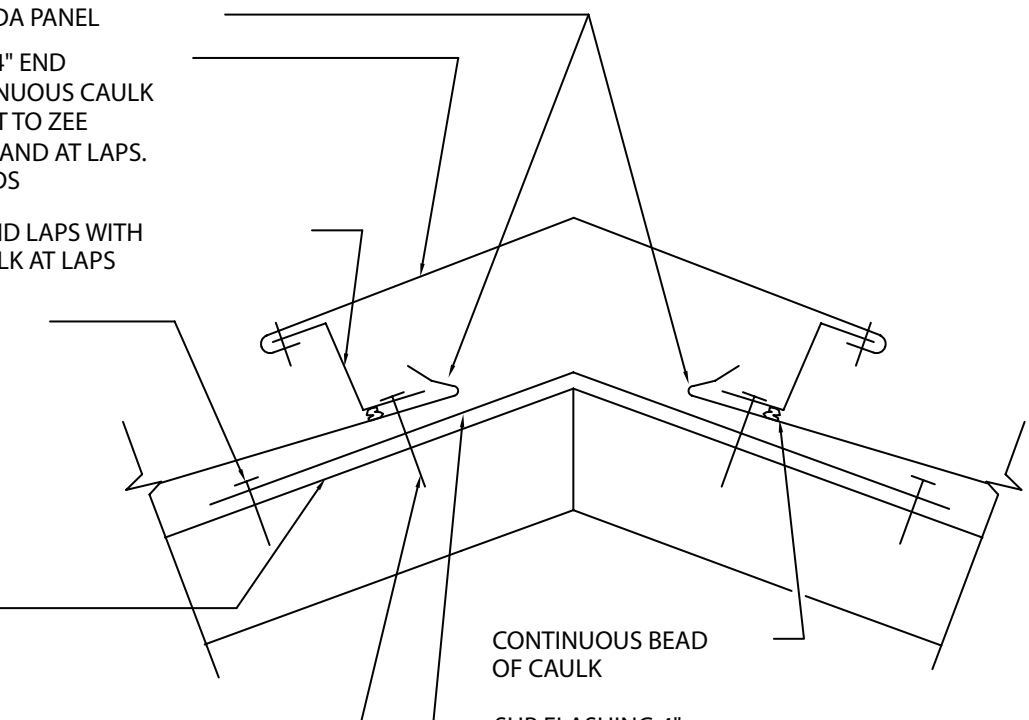

1. ALL CAULKING AND FASTENERS ARE ITEM TO BE FURNISHED AND INSTALLED BY THE
 ROOFING INSTALLER AT THE DISCRETION OF THE ARCHITECT

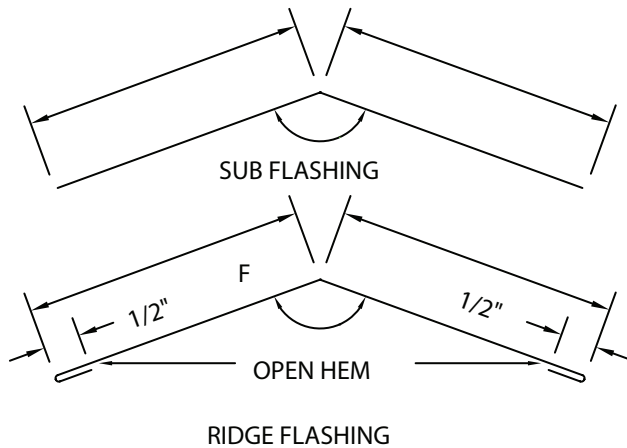

F = FINISH SIDE

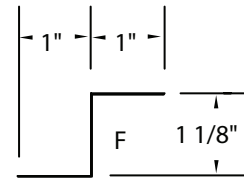

ZEE CLOSURE



BERRIDGE
 MANUFACTURING
 COMPANY

**RIDGE DETAIL
 OPEN FRAMING**

Bermuda Panel System

DATE: 08-15-06

PAGE/FILE
 BP-21

BERRIDGE BERMUDA PANEL
 RIDGE FLASHING 4" END
 LAPS WITH CONTINUOUS CAULK
 AT LAPS, POP RIVET TO BERMUDA
 PANEL 40" O.C., AND AT LAPS.
 CAULK RIVET HEADS

CONTINUOUS BEAD
 OF CAULK

30 FELT
 UNDERLAYMENT

SOLID SHEATHING

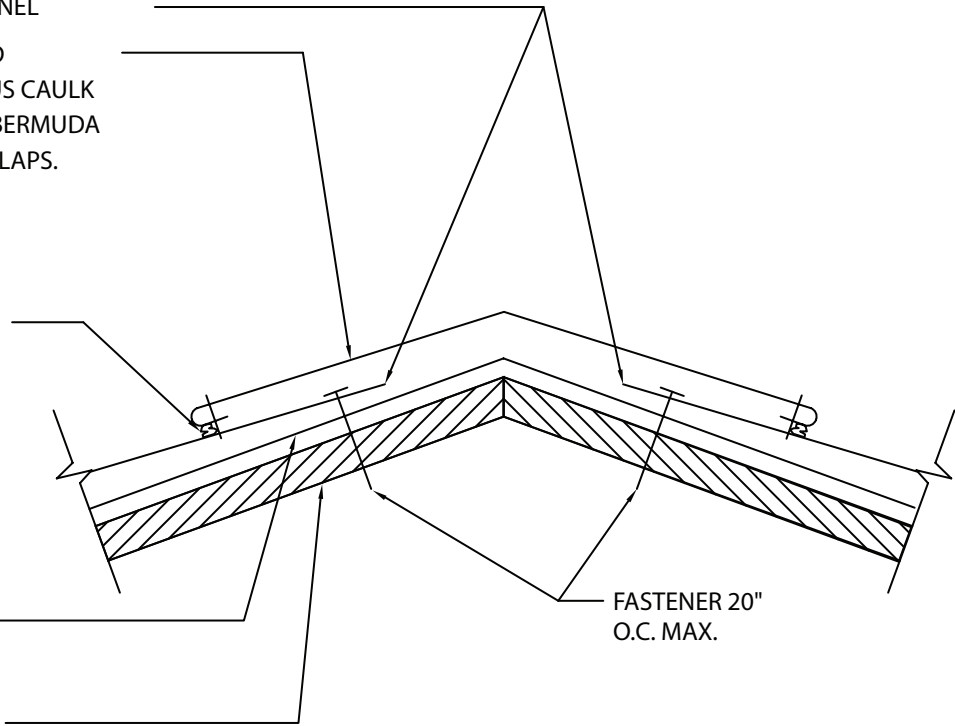

FASTENER 20"
 O.C. MAX.

1. SOLID SHEATHING (BY OTHERS) TO BE MINIMUM 1/2" PLYWOOD OR EQUIVALENT IN STRENGTH FOR HOLDING POWER OF FASTENERS.
2. ALL FELT UNDERLAYMENT, CAULKING AND FASTENERS ARE ITEMS TO BE FURNISHED AND INSTALLED BY THE ROOFING INSTALLER AT THE DISCRETION OF THE ARCHITECT.

F = FINISH SIDE

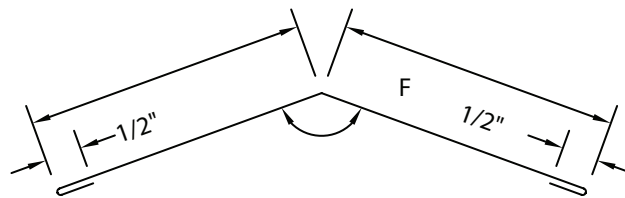

RIDGE FLASHING



**BERRIDGE
 MANUFACTURING
 COMPANY**

Roofs of Distinction

**RIDGE DETAIL
 SOLID SUBSTRATE**

Bermuda Panel System

DATE: 08-15-06

PAGE/FILE
 BP-22

RIDGE CAP; 4" END LAPS WITH CONTINUOUS CAULK AT LAPS, POP RIVET TO ZEE CLOSURE AT 40" O.C. MAX. CAULK RIVET HEADS

ZEE CLOSURE
4" END LAP WITH
CONTINUOUS CAULK
AT LAPS

BARRIDGE BERMUDA PANEL

CONTINUOUS BEAD OF
CAULK

LAP FELT OVER RIDGE

FASTENERS; 20" O.C. MAX.

FASTENERS; 40" O.C.
MAX. CAULK
FASTENER HEAD

30 FELT
UNDERLAYMENT
SOLID SHEATHING

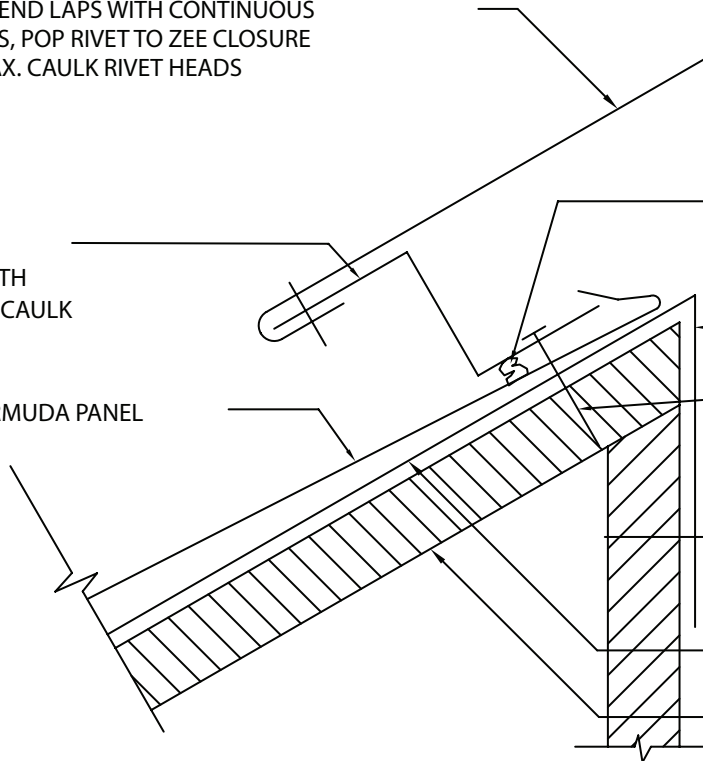

1. SOLID SHEATHING (BY OTHERS) TO BE MINIMUM 1/2" PLYWOOD OR EQUIVALENT IN STRENGTH FOR HOLDING POWER OF FASTENERS.
2. ALL FELT UNDERLAYMENT, CAULKING, AND FASTENERS, ARE ITEMS TO BE FURNISHED AND INSTALLED BY THE ROOFING INSTALLER AT THE DISCRETION OF THE ARCHITECT.

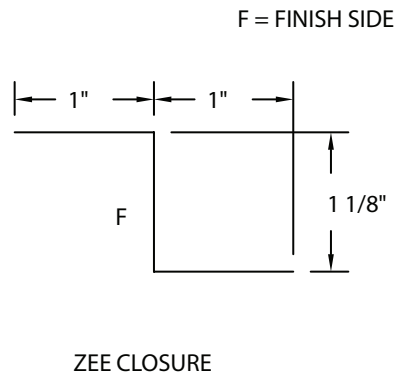
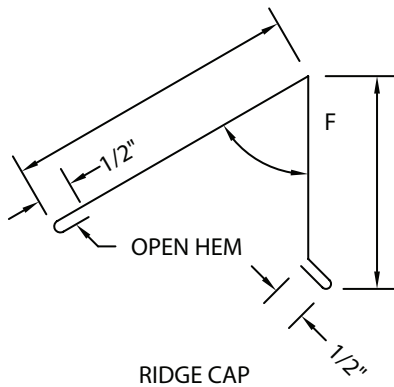

**BERRIDGE
MANUFACTURING
COMPANY**

Roofs of Distinction

SHED ROOF RIDGE CAP DETAIL

Bermuda Panel System

DATE: 08-15-06

PAGE/FILE
BP-23

HIP CAP; INSTALL WITH EACH COURSE OF PANEL (SEE BELOW)

BERRIDGE BERMUDA PANEL

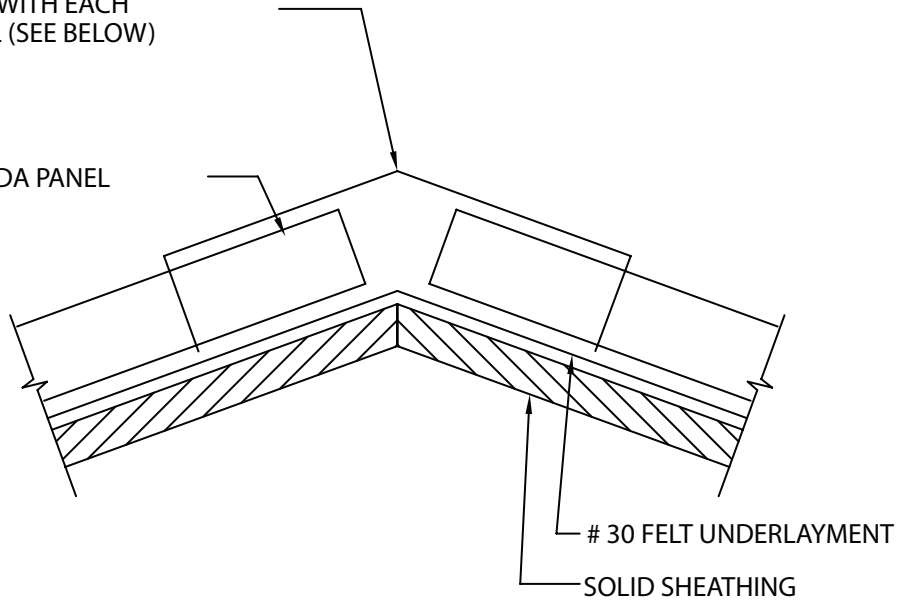

1. SOLID SHEATHING (BY OTHERS) TO BE MINIMUM 1/2" PLYWOOD OR EQUIVALENT IN STRENGTH FOR HOLDING POWER OF FASTENERS.
2. ALL FELTING UNDERLAYMENT, CAULKING, AND FASTENERS, ARE ITEMS TO BE FURNISHED AND INSTALLED BY THE ROOFING INSTALLER AT THE DISCRETION OF THE ARCHITECT.

BERRIDGE BERMUDA PANEL ABOVE HIP CAP, FIELD CUT TO ALIGN WITH LINE OF HIP

HIP CAP; INSTALL WITH EACH COURSE OF PANEL

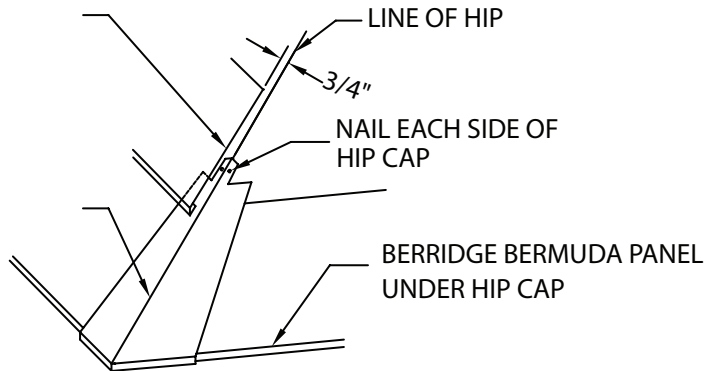

**BERRIDGE
MANUFACTURING
COMPANY**

Roofs of Distinction

HIP DETAIL

Bermuda Panel System

DATE: 08-15-06

PAGE/FILE
BP-24

BERRIDGE BERMUDA PANEL

HIP FLASHING 4" END LAPS WITH CONTINUOUS CAULK AT LAPS, POP RIVET TO CHANNEL CLOSURE 40" O.C. MAX. AND AT LAPS. CAULK RIVET HEADS

CHANNEL CLOSURE 4" END LAPS WITH CONTINUOUS CAULK AT LAPS

BERRIDGE BERMUDA PANEL

SOLID SHEATHING

FASTENER 20" O.C. MAX.

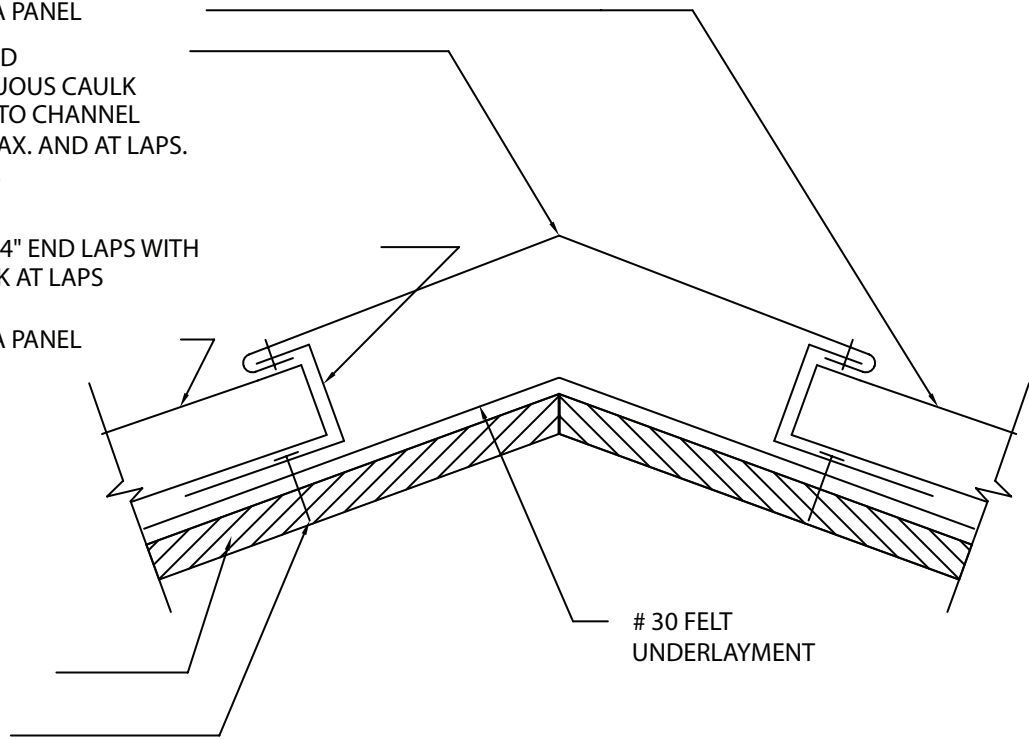

1. SOLID SHEATHING (BY OTHERS) TO BE MINIMUM 1/2" PLYWOOD OR EQUIVALENT IN STRENGTH FOR HOLDING POWER OF FASTENERS.
2. ALL FELT UNDERLAYMENT, CAULKING AND FASTENERS ARE ITEMS TO BE FURNISHED AND INSTALLED BY THE ROOFING INSTALLER AT THE DISCRETION OF THE ARCHITECT.

F = FINISH SIDE

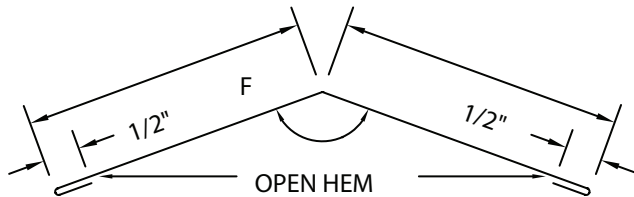

HIP FLASHING

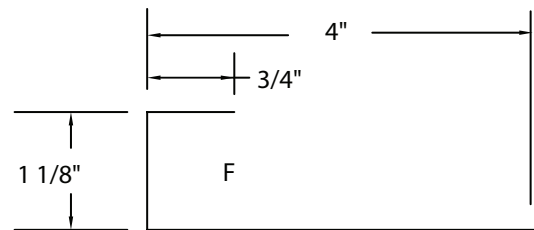

CHANNEL CLOSURE



BERRIDGE
MANUFACTURING
COMPANY

HIP DETAIL

Bermuda Panel System

DATE: 08-15-06

PAGE/FILE
BP-25

SECTION VIEW

FIELD FORM END OF RIDGE FLASHING
AND EXTEND UNDER CONTINUOUS CLEAT

RIDGE FLASHING; 4" END LAPS
WITH CONTINUOUS CAULK AT LAPS

FIELD TAPERED ZEE CLOSURE
WITH CONTINUOUS CAULK UNDER
ZEE CLOSURE

CONTINUOUS CLEAT;
DO NOT CAULK ON
OR UNDER CLEAT

BERRIDGE BERMUDA PANEL

30 FELT
UNDERLAYMENT

FASTENERS; 20" O.C. MAX.
PLACE A DAB OF CAULK
AT FASTENER LOCATION
DRIVE FASTENER AND
CAULK FASTENER HEAD

BP-20

SOLID SHEATHING
VALLEY FLASHING; 12" LAPS WITH
CONTINUOUS CAULK AT LAPS

PLAN VIEW

MAIN ROOF
PANELS

RIDGE FLASHING

CONTINUOUS CLEAT

VALLEY FLASHING

DORMER PANEL

SLOPE

SLOPE

SLOPE



BERRIDGE
MANUFACTURING
COMPANY

RIDGE TERMINATION AT
DORMER VALLEY

Bermuda Panel System

DATE: 08-15-06

PAGE/FILE
BP-26

BERRIDGE BERMUDA PANEL

SPECIAL CHANNEL CLOSURE
4" END LAPS WITH
CONTINUOUS CAULK AT LAPS

CONTINUOUS BEADS OF CAULK

GABLE FLASHING; 4" END LAPS WITH
CONTINUOUS CAULK AT LAPS

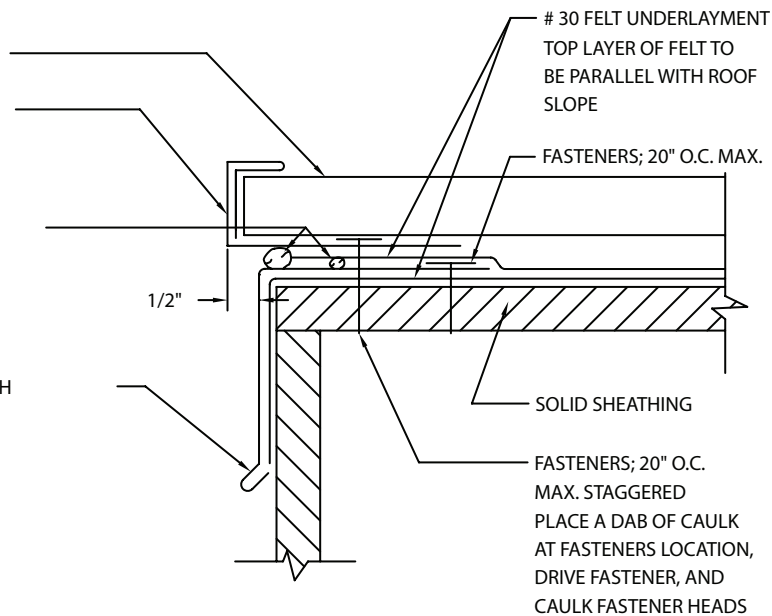

1. SOLID SHEATHING (BY OTHERS) TO BE MINIMUM 1/2" PLYWOOD OR EQUIVALENT IN STRENGTH FOR HOLDING POWER OF FASTENERS.

2. ALL FELT UNDERLAYMENT, CAULKING, AND FASTENERS, ARE ITEMS TO BE FURNISHED AND INSTALLED BY THE ROOFING INSTALLER AT THE DISCRETION OF THE ARCHITECT.

F = FINISH SIDE

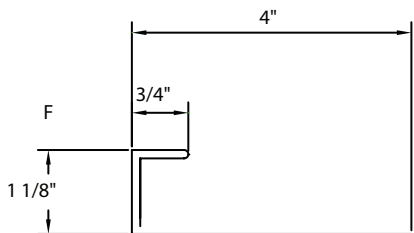

SPECIAL CHANNEL CLOSURE

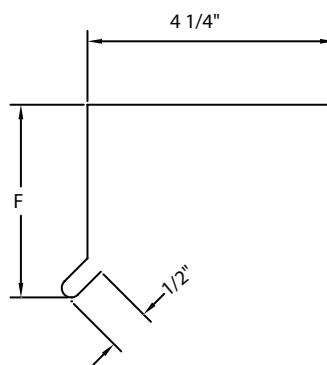

GABLE FLASHING



BERRIDGE
MANUFACTURING
COMPANY

Roofs of Distinction

GABLE DETAIL SOLID SUBSTRATE

Bermuda Panel System

DATE: 08-15-06

PAGE/FILE
BP-30

BERRIDGE BERMUDA PANEL
 SPECIAL CHANNEL CLOSURE
 4" END LAPS WITH
 CONTINUOUS CAULK AT LAPS
 CONTINUOUS BEAD OF CAULK

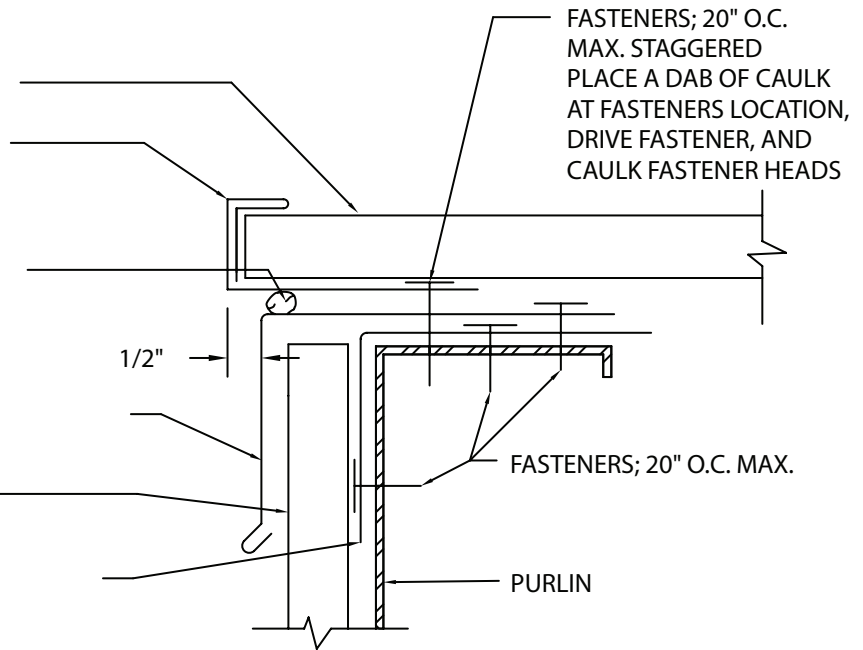

GABLE FLASHING; 4" END LAPS WITH
 CONTINUOUS CAULK AT LAPS
 BERRIDGE WALL OR
 FASCIA PANEL
 SUB FLASHING; 4" END LAPS WITH
 CONTINUOUS CAULK AT LAPS

1. ALL CAULKING, AND FASTENERS, ARE ITEMS TO BE FURNISHED AND INSTALLED BY THE ROOFING INSTALLER AT THE DISCRETION OF THE ARCHITECT.

F = FINISH SIDE

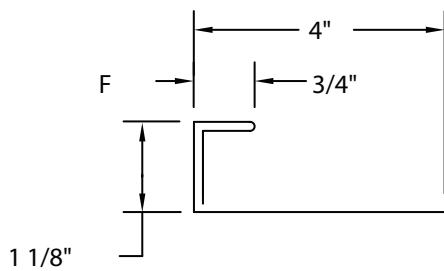

SPECIAL CHANNEL CLOSURE

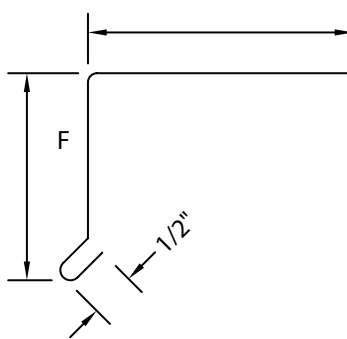

GABLE FLASHING

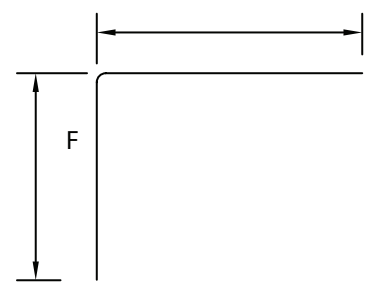

SUB FLASHING



**BERRIDGE
 MANUFACTURING
 COMPANY**

Roofs of Distinction

**GABLE DETAIL
 OPEN FRAMING**

Bermuda Panel System

DATE: 08-15-06

PAGE/FILE
 BP-31

BERRIDGE WALL OR
FASCIA PANEL

CHANNEL CLOSURE; 4" END LAPS WITH
CONTINUOUS CAULK AT LAPS.

COUNTER FLASHING; 4" END LAPS
WITH CONTINUOUS CAULK AT LAPS.
POP RIVET TO ZEE CLOSURE 40" O.C. MAX.
AND AT LAPS. CAULK RIVET HEADS.

SUB-FLASHING; 4" END LAPS WITH
CONTINUOUS CAULK AT LAPS.

ZEE CLOSURE; 4" END LAPS WITH
CONTINUOUS CAULK AT LAPS.

BERRIDGE BERMUDA PANEL

30 FELT UNDERLAYMENT

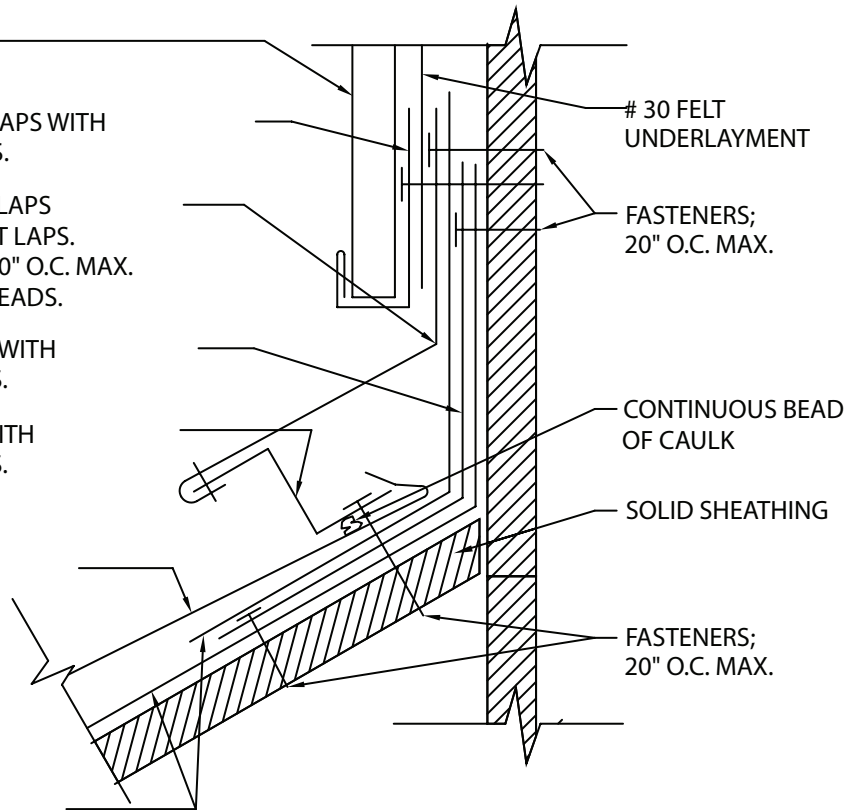

1. SOLID SHEATHING (BY OTHERS) TO BE MINIMUM 1/2" PLYWOOD OR EQUIVALENT IN STRENGTH FOR HOLDING POWER OF FASTENERS.
2. ALL FELT UNDERLAYMENT, CAULKING, AND FASTENERS, ARE ITEMS TO BE FURNISHED AND INSTALLED BY THE ROOFING INSTALLER AT THE DISCRETION OF THE ARCHITECT.

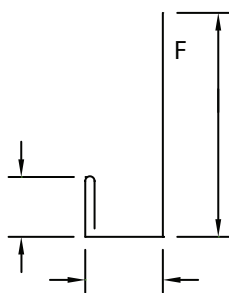

CHANNEL CLOSURE

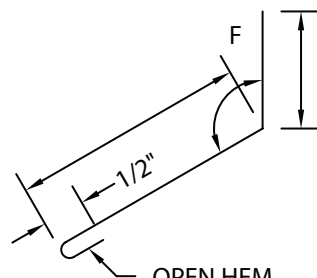

COUNTER FLASHING

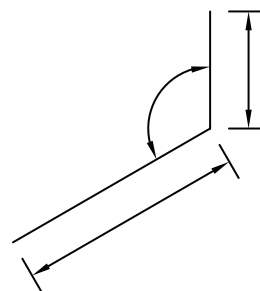

SUB-FLASHING

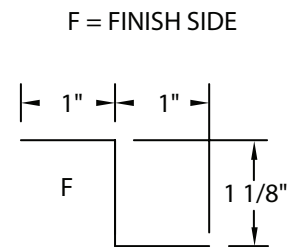

ZEE CLOSURE



**BERRIDGE
MANUFACTURING
COMPANY**

Roofs of Distinction

HEAD WALL DETAIL

Bermuda Panel System

DATE: 08-15-06

PAGE/FILE
BP-40

BERRIDGE WALL OR FASCIA PANEL

CHANNEL CLOSURE; 4" END LAPS WITH CONTINUOUS CAULK AT LAPS.

COUNTER FLASHING; 4" END LAPS WITH CONTINUOUS CAULK AT LAPS. POP RIVET TO ZEE CLOSURE 40" O.C. AND AT LAPS, CAULK RIVET HEADS.

ZEE CLOSURE; 4" END LAPS WITH CONTINUOUS CAULK AT LAPS.

BERRIDGE BERMUDA PANEL

FASTENERS; AT EVERY PURLIN

PURLIN

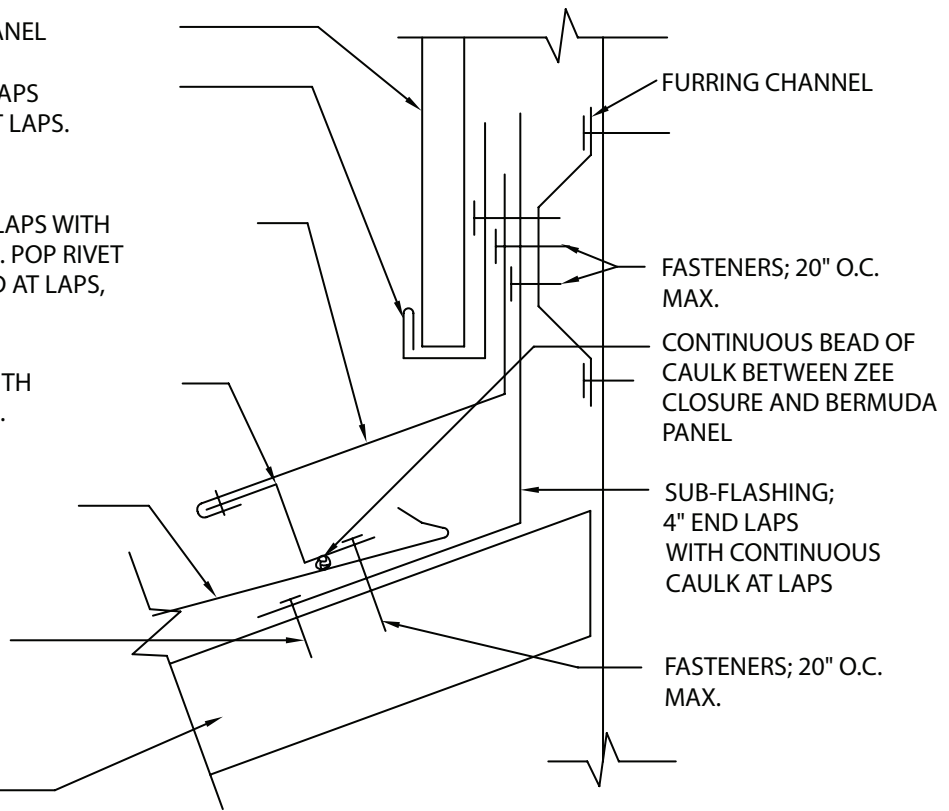

1. ALL CAULKING, AND FASTENERS, ARE ITEMS TO BE FURNISHED AND INSTALLED BY THE ROOFING INSTALLER AT THE DISCRETION OF THE ARCHITECT.

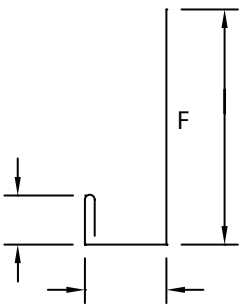

CHANNEL CLOSURE

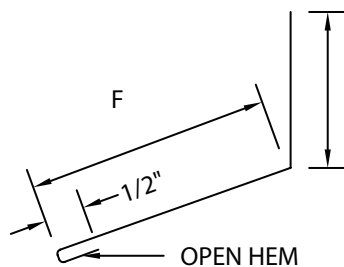

COUNTER FLASHING

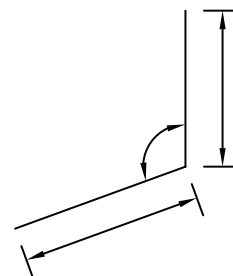

SUB-FLASHING

F = FINISH SIDE

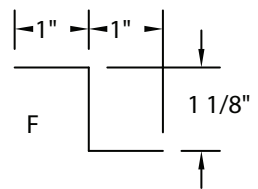

ZEE CLOSURE



**BERRIDGE
MANUFACTURING
COMPANY**

Roofs of Distinction

HEAD WALL DETAIL OPEN FRAMING

Bermuda Panel System

DATE: 08-15-06

PAGE/FILE

BP-41

CONTINUOUS BEAD OF CAULK AT REGLET

REGLET FLASHING; 4" END LAPS WITH CONTINUOUS CAULK AT LAPS.

30 FELT UNDERLAYMENT

COUNTER FLASHING; 4" END LAPS WITH CONTINUOUS CAULK AT LAPS. POP RIVET TO ZEE CLOSURE 40" O.C. AND AT LAPS. CAULK RIVET HEADS.

ZEE CLOSURE; 4" END LAPS WITH CONTINUOUS CAULK AT LAPS.

BERRIDGE BERMUDA PANEL

SOLID SHEATHING

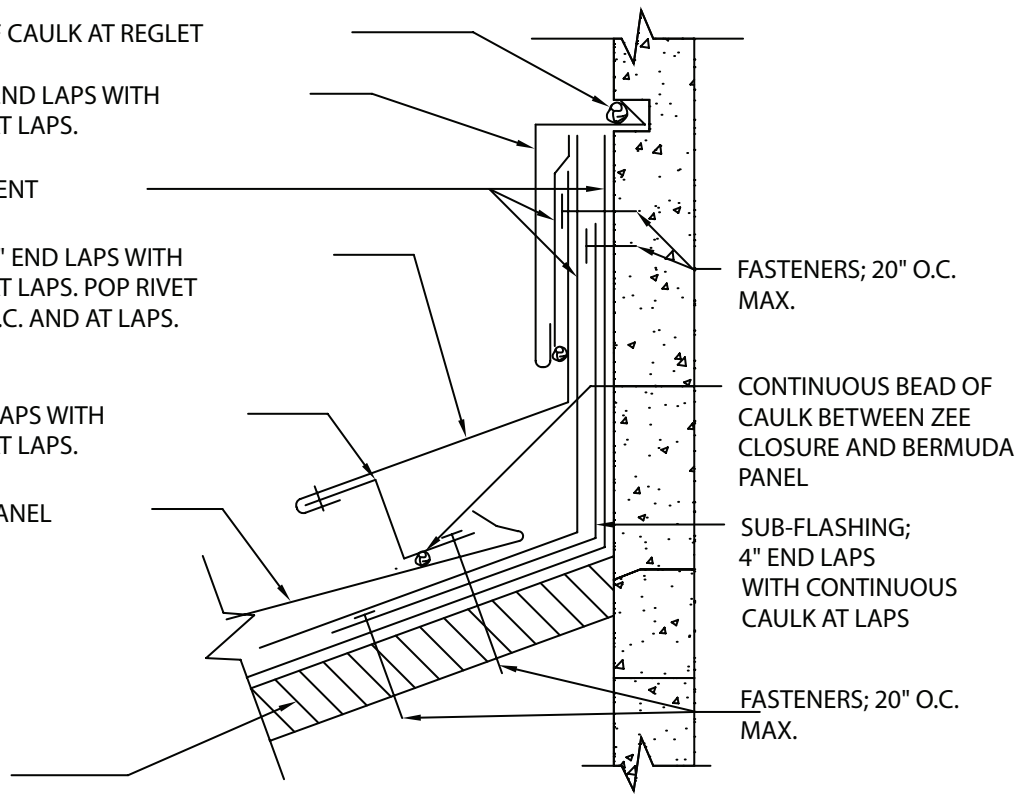

1. SOLID SHEATHING (BY OTHERS) TO BE MINIMUM 1/2" PLYWOOD OR EQUIVALENT IN STRENGTH FOR HOLDING POWER OF FASTENERS.

2. ALL FELT UNDERLAYMENT, CAULKING, AND FASTENERS, ARE ITEMS TO BE FURNISHED AND INSTALLED BY THE ROOFING INSTALLER AT THE DISCRETION OF THE ARCHITECT.

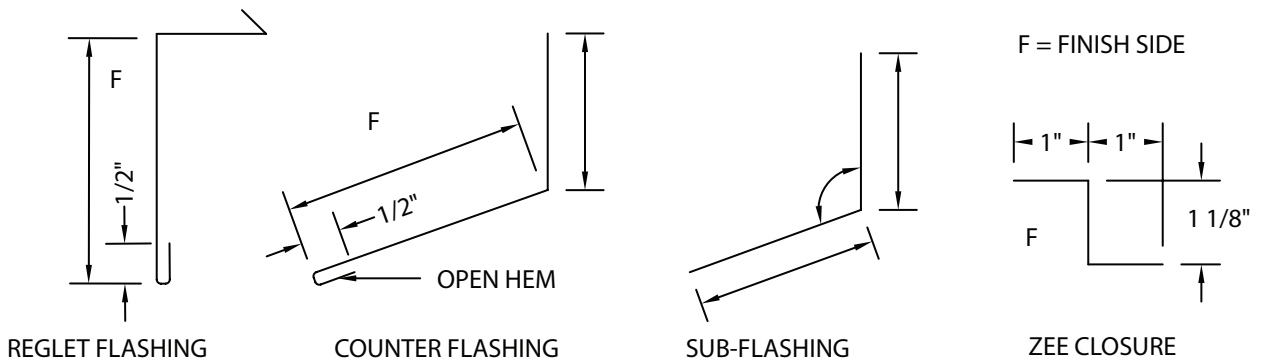

BERRIDGE
MANUFACTURING
COMPANY

HEAD WALL DETAIL SOLID SUBSTRATE

Bermuda Panel System

DATE: 08-15-06

PAGE/FILE
BP-42

CAP FLASHING; 4" END LAPS WITH CONTINUOUS CAULK AT LAPS. POP RIVET TO COUNTER FLASHING 40" O.C. MAX. CAULK ALL RIVET HEADS.

FASTENERS; 20" O.C. MAX.

COUNTERFLASHING; 4" END LAPS WITH CONTINUOUS CAULK AT LAPS. POP RIVET TO ZEE CLOSURE 40" O.C. MAX. AND AT LAPS. CAULK RIVET HEADS.

SUB-FLASHING; 4" END LAPS WITH CONTINUOUS CAULK AT LAPS.

30 FELT UNDERLAYMENT

ZEE CLOSURE; 4" END LAPS WITH CONTINUOUS CAULK AT LAPS.

BERRIDGE BERMUDA PANEL

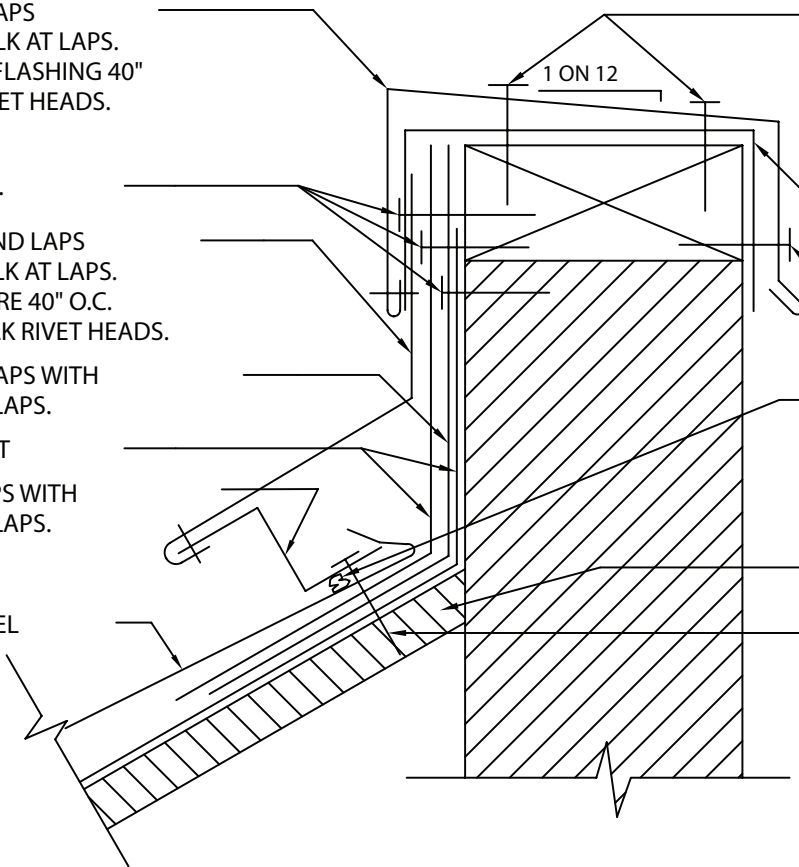

FASTENERS AT LAPS AND STAGGERED; 20" O.C. AND CAULK FASTENER HEADS

30 FELT UNDERLAYMENT

FASTENERS; 40" O.C. MAX. CAULK FASTENER HEADS

CONTINUOUS BEAD OF CAULK

SOLID SHEATHING

FASTENERS; 20" O.C. Max.

1. SOLID SHEATHING (BY OTHERS) TO BE MINIMUM 1/2" PLYWOOD OR EQUIVALENT IN STRENGTH FOR HOLDING POWER OF FASTENERS.
2. ALL FELT UNDERLAYMENT, CAULKING, AND FASTENERS, ARE ITEMS TO BE FURNISHED AND INSTALLED BY THE ROOFING INSTALLER AT THE DISCRETION OF THE ARCHITECT.

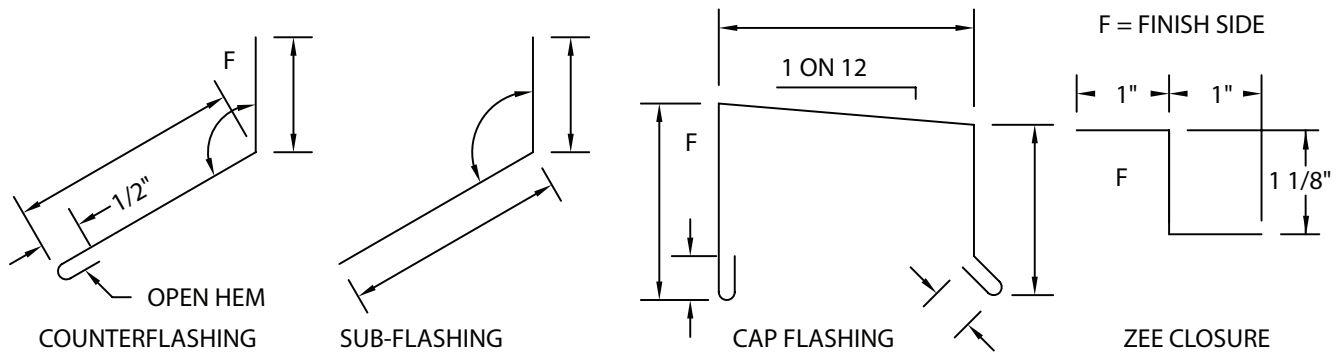

BERRIDGE
B
BERRIDGE MANUFACTURING COMPANY
Roofs of Distinction

PARAPET DETAIL
Bermuda Panel System

DATE: 08-15-06
 PAGE/FILE
 BP-43

BERRIDGE WALL OR FASCIA PANEL

COUNTERFLASHING; 4" END LAPS WITH CONTINUOUS CAULK AT LAPS

BERRIDGE BERMUDA PANEL

30 FELT UNDERLAYMENT; TOP LAYER TO BE PARALLEL WITH ROOF SLOPE

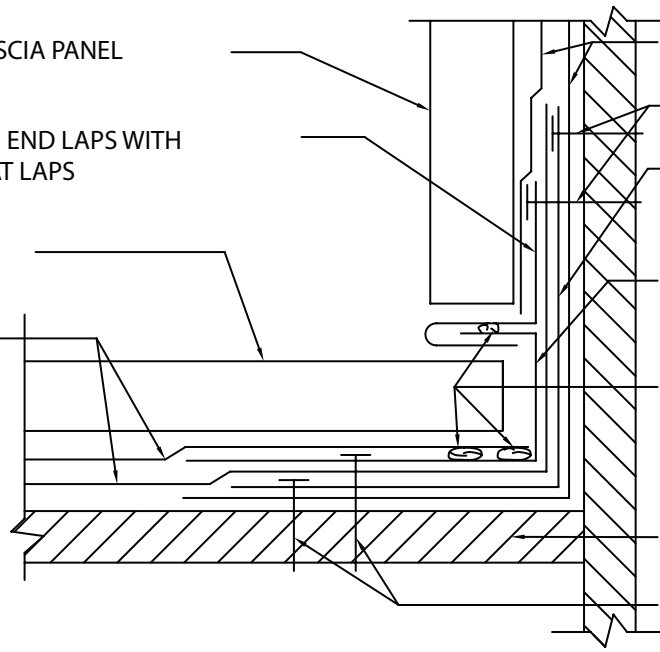

30 FELT UNDERLAYMENT

FASTENERS; 20" O.C. MAX.

SUB-FLASHING; 4" END LAPS WITH CONTINUOUS CAULK AT LAPS

CLOSURE CHANNEL; 4" END LAPS WITH CONTINUOUS CAULK AT LAPS

CONTINUOUS BEAD OF CAULK

SOLID SHEATHING

FASTENERS; 20" O.C. MAX.

1. SOLID SHEATHING (BY OTHERS) TO BE MINIMUM 1/2" PLYWOOD OR EQUIVALENT IN STRENGTH FOR HOLDING POWER OF FASTENERS.

2. ALL FELT UNDERLAYMENT, CAULKING, AND FASTENERS, ARE ITEMS TO BE FURNISHED AND INSTALLED BY THE ROOFING INSTALLER AT THE DISCRETION OF THE ARCHITECT.

F = FINISH SIDE

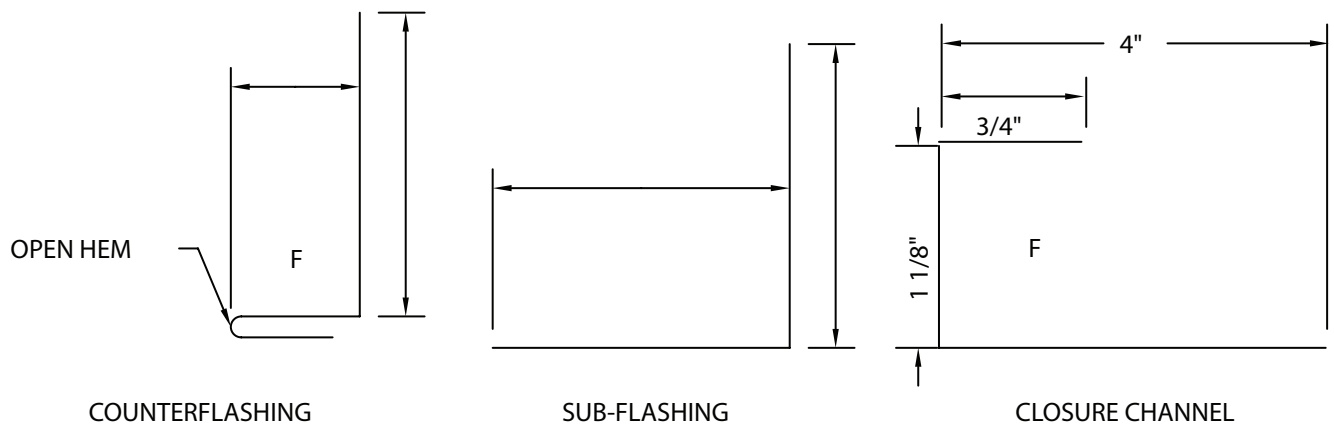

COUNTERFLASHING

SUB-FLASHING

CLOSURE CHANNEL



**BERRIDGE
MANUFACTURING
COMPANY**

Roofs of Distinction

RAKE WALL DETAIL
COUNTER FLASHING
SOLID SUBSTRATE

DATE: 08-15-06

Bermuda Panel System

PAGE/FILE
BP-50

CONTINUOUS CAULK AT REGLET

REGLETFLASHING; 4" END LAPS WITH CONTINUOUS CAULK AT LAPS

COUNTERFLASHING; 4" END LAPS WITH CONTINUOUS CAULK AT LAPS

CONTINUOUS BEAD OF CAULK

BERRIDGE BERMUDA PANEL

30 FELT UNDERLAYMENT (TOP LAYER MUST BE PARALLEL WITH ROOF SLOPE)

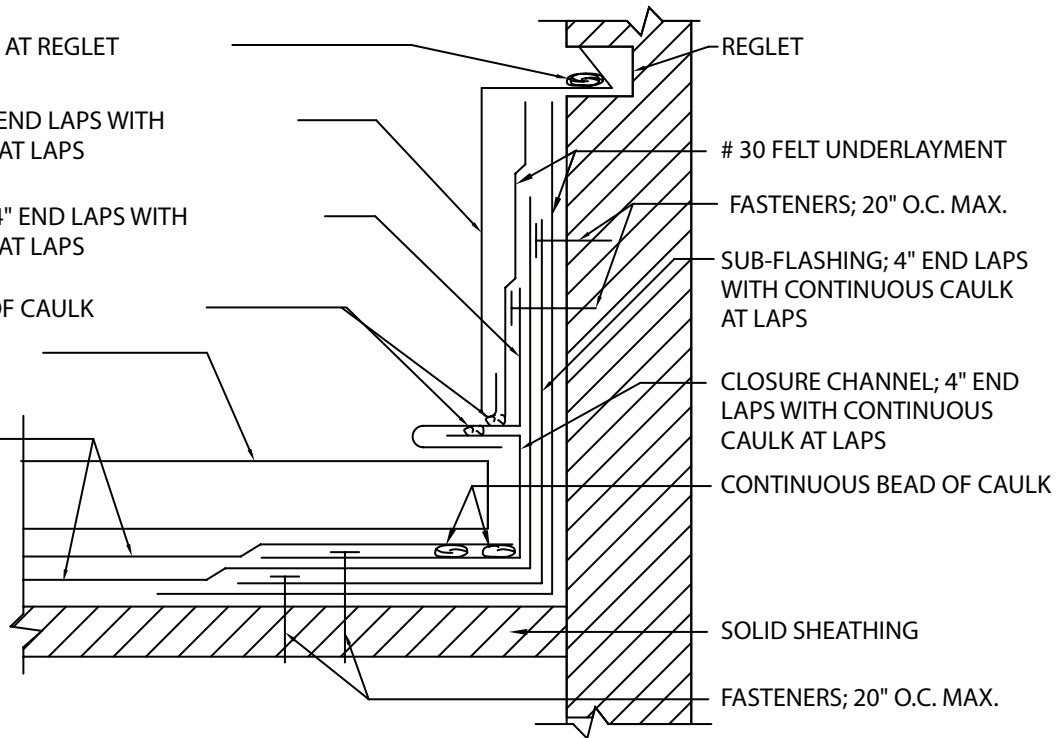

1. SOLID SHEATHING (BY OTHERS) TO BE MINIMUM 1/2" PLYWOOD OR EQUIVALENT IN STRENGTH FOR HOLDING POWER OF FASTENERS.

2. ALL FELT UNDERLAYMENT, CAULKING, AND FASTENERS, ARE ITEMS TO BE FURNISHED AND INSTALLED BY THE ROOFING INSTALLER AT THE DISCRETION OF THE ARCHITECT.

F = FINISH SIDE

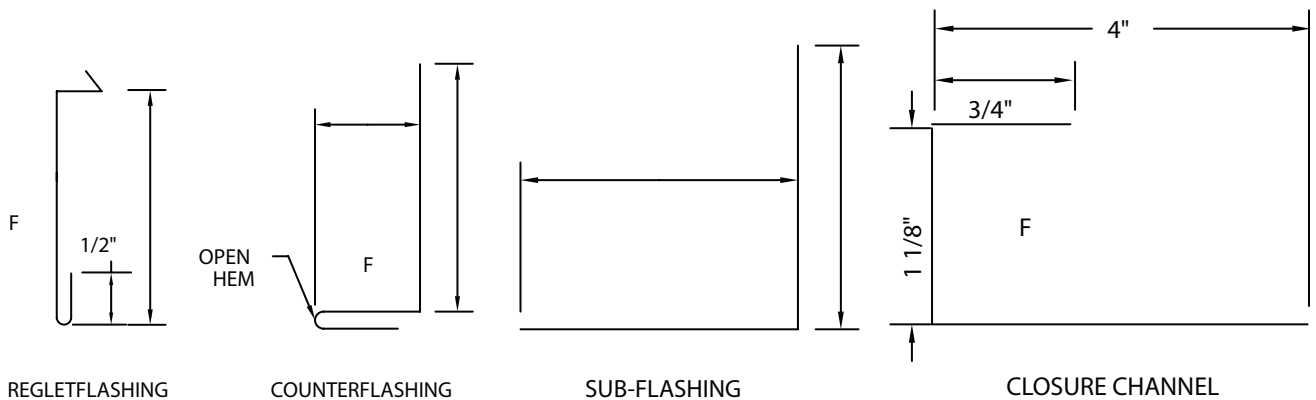

**BERRIDGE
MANUFACTURING
COMPANY**

Roofs of Distinction

RAKE WALL DETAIL
COUNTER FLASHING
SOLID SUBSTRATE

DATE: 08-15-06

PAGE/FILE
BP-51

Bermuda Panel System

BERRIDGE WALL OR FASCIA PANEL

DRIP FLASHING; 4" END LAPS WITH CONTINUOUS CAULK AT LAPS

COUNTERFLASHING; 4" END LAPS WITH CONTINUOUS CAULK AT LAPS

CONTINUOUS BEAD OF CAULK

BERRIDGE BERMUDA PANEL

FASTENERS; 20" O.C. MAX. PLACE A DAB OF CAULK AT FASTENER LOCATION DRIVE FASTENER AND CAULK FASTENER HEAD.

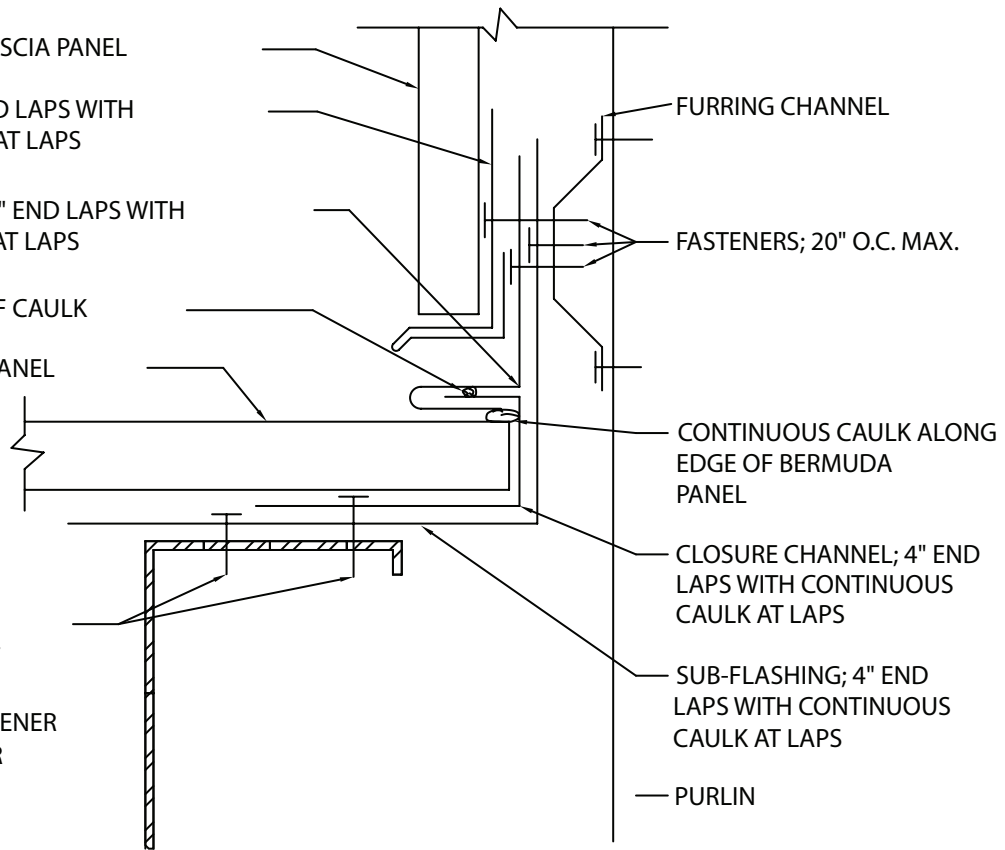

1. ALL CAULKING, AND FASTENERS, ARE ITEMS TO BE FURNISHED AND INSTALLED BY THE ROOFING INSTALLER AT THE DISCRETION OF THE ARCHITECT.

F = FINISH SIDE

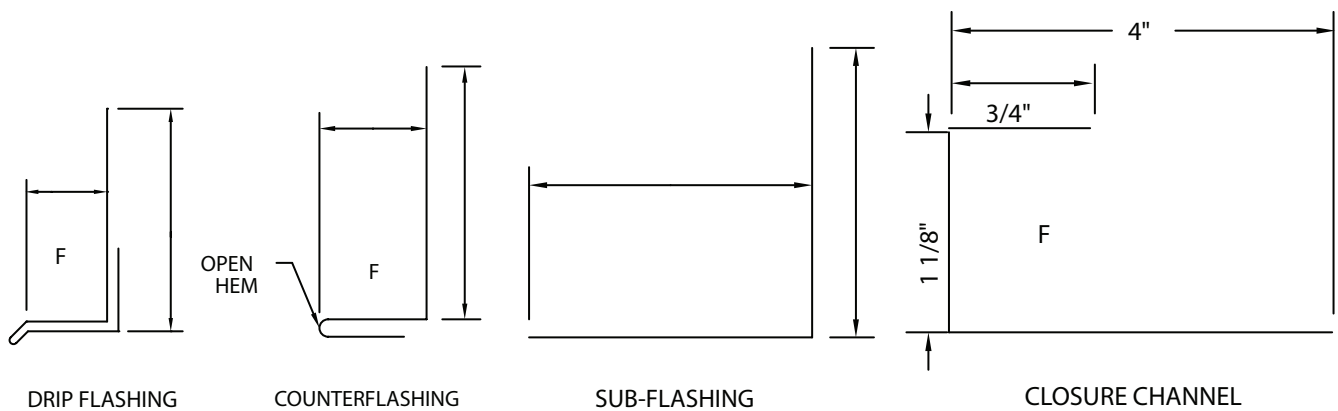

**BERRIDGE
MANUFACTURING
COMPANY**

Roofs of Distinction

RAKE WALL DETAIL OPEN FRAMING

Bermuda Panel System

DATE: 08-15-06

PAGE/FILE
BP-52

BERRIDGE WALL OR FASCIA PANEL

DRIP FLASHING; 4" END LAPS WITH CONTINUOUS CAULK AT LAPS

STEP FLASHING; 4" END LAPS WITH CONTINUOUS CAULK AT LAPS, SET FLASHING TIGHT ON TO PANEL

BERRIDGE BERMUDA PANEL;

30 FELT UNDERLAYMENT; TOP LAYER TO BE PARALLEL WITH ROOF SLOPE

SUB-FLASHING; 4" END LAPS WITH CONTINUOUS CAULK AT LAPS

FASTENERS; 20" O.C. MAX.

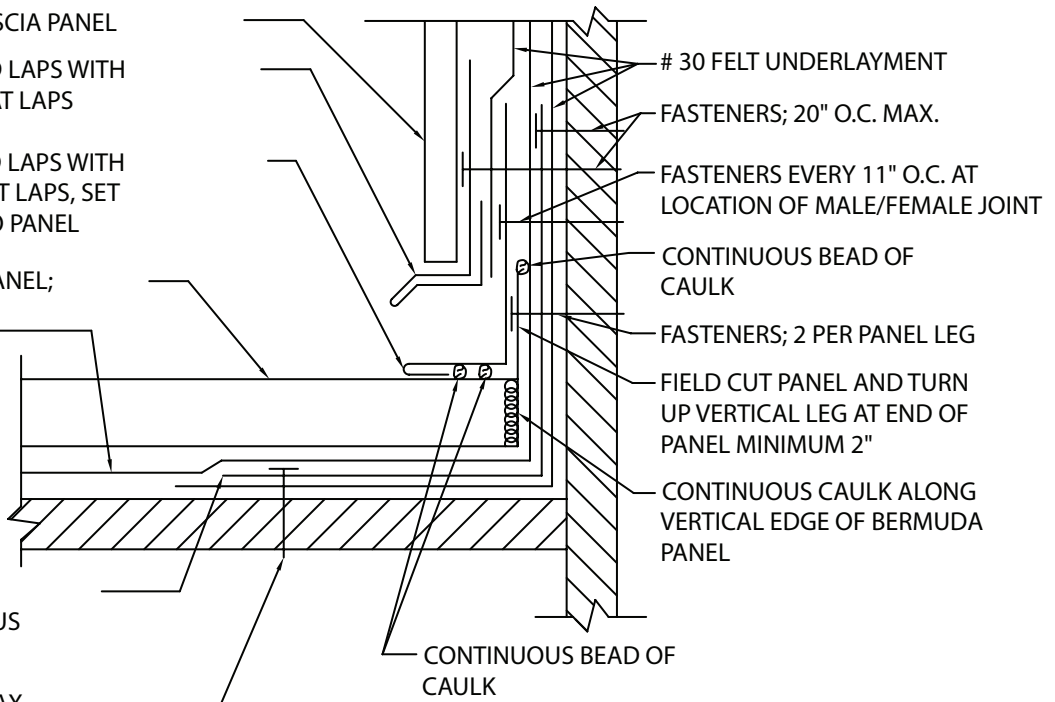

1. SOLID SHEATHING (BY OTHERS) TO BE MINIMUM 1/2" PLYWOOD OR EQUIVALENT IN STRENGTH FOR HOLDING POWER OF FASTENERS.

2. ALL FELT UNDERLAYMENT, CAULKING, AND FASTENERS, ARE ITEMS TO BE FURNISHED AND INSTALLED BY THE ROOFING INSTALLER AT THE DISCRETION OF THE ARCHITECT.

F = FINISH SIDE

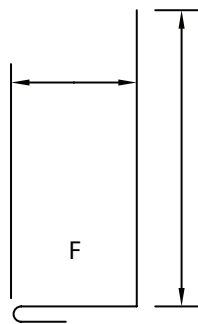

STEP FLASHING

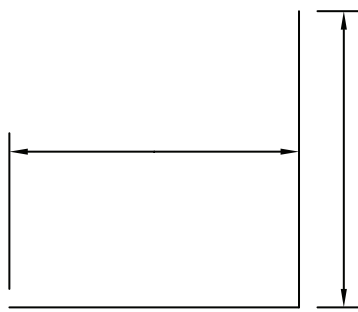

SUB-FLASHING

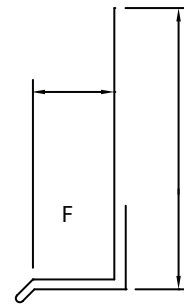

DRIP FLASHING



BERRIDGE
MANUFACTURING
COMPANY

RAKE WALL DETAIL
STEP FLASHING
SOLID SUBSTRATE

Bermuda Panel System

DATE: 08-15-06

PAGE/FILE
BP-53

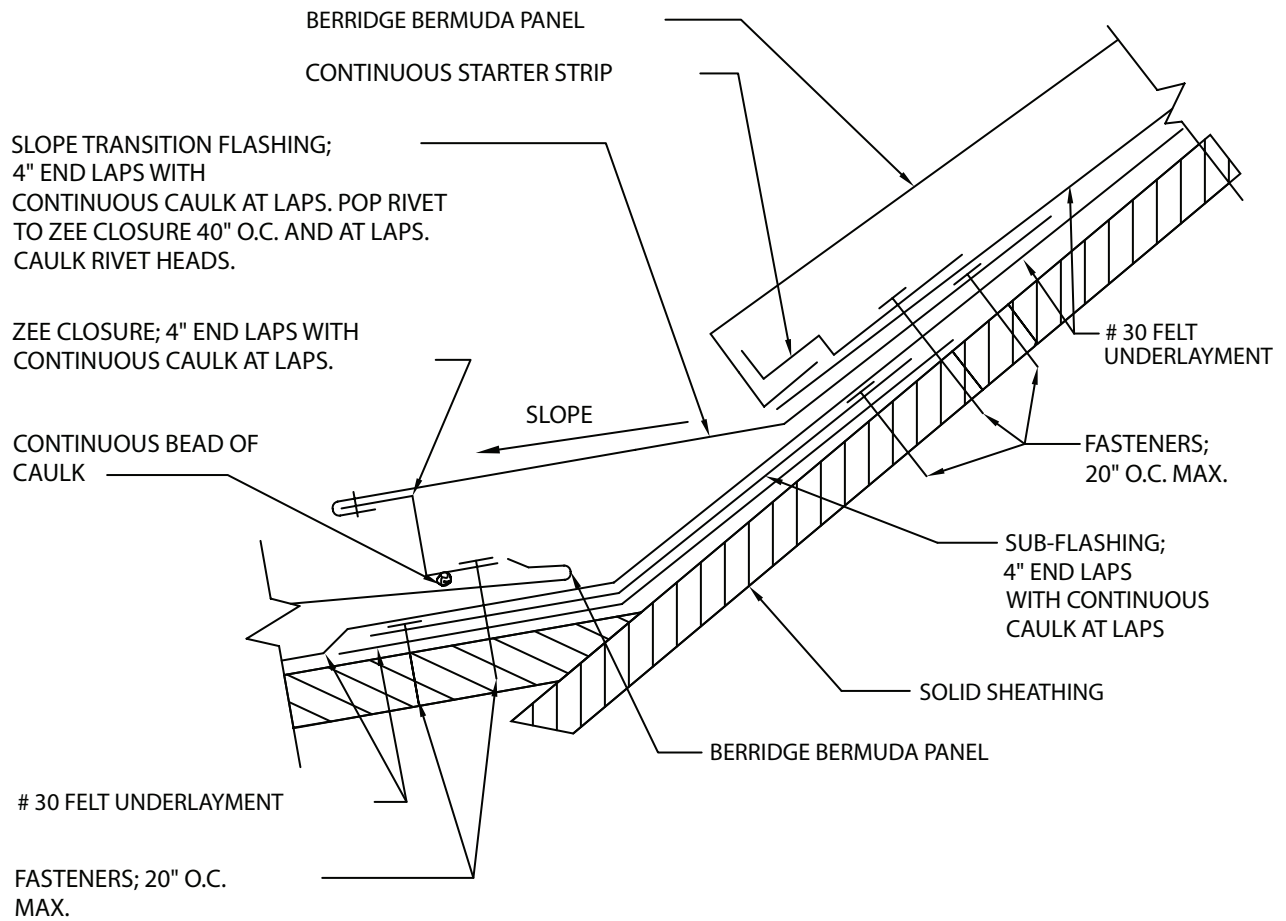

1. SOLID SHEATHING (BY OTHERS) TO BE MINIMUM 1/2" PLYWOOD OR EQUIVALENT IN STRENGTH FOR HOLDING POWER OF FASTENERS.
2. ALL FELT UNDERLAYMENT, CAULKING, AND FASTENERS, ARE ITEMS TO BE FURNISHED AND INSTALLED BY THE ROOFING INSTALLER AT THE DISCRETION OF THE ARCHITECT.

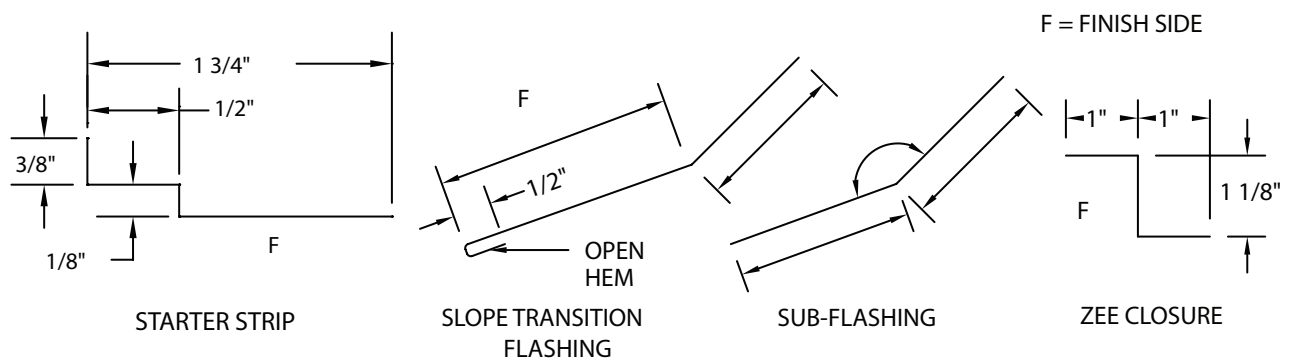

**BERRIDGE
MANUFACTURING
COMPANY**

Roofs of Distinction

SLOPE TRANSITION DETAIL SOLID SUBSTRATE

Bermuda Panel System

DATE: 08-15-06

PAGE/FILE
BP-60

BERRIDGE BERMUDA PANEL

SPECIAL VALLEY CAP; PLACE INTO FEMALE LOCK OF PANEL ABOVE AND FASTEN TO BUTT OF PANELS BEING COVERED

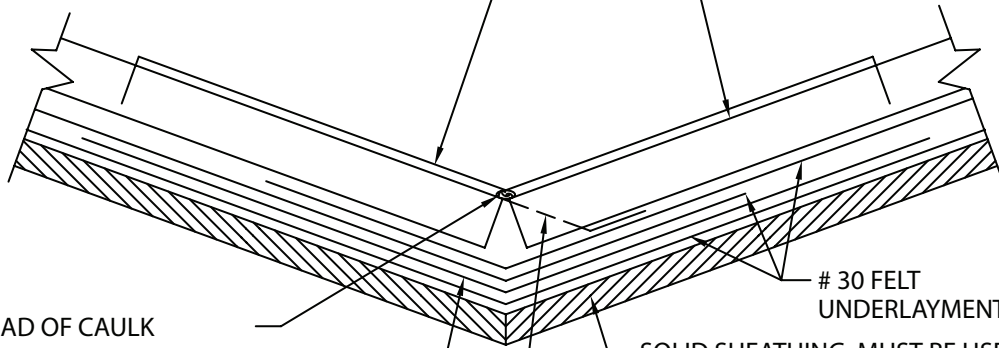

CONTINUOUS BEAD OF CAULK

30 FELT UNDERLAYMENT

SOLID SHEATHING; MUST BE USED AT ALL VALLEYS SEE DETAIL BP-74

VALLEY FLASHING; 12" END LAPS WITH 2 BEADS CONTINUOUS CAULK AT LAPS, VALLEY LEGS MIN. 21" EACH SIDE.

BERMUDA PANEL FIELD CUT OFF BUTT AND LAP UNDER OPPOSITE PANEL

1. SOLID SHEATHING (BY OTHERS) TO BE A MINIMUM OF 1/2" PLYWOOD OR EQUIVALENT IN STRENGTH FOR HOLDING POWER OF FASTENERS.
2. ALL FELT UNDERLAYMENT, CAULKING, AND FASTENERS, ARE ITEMS TO BE FURNISHED AND INSTALLED BY THE ROOFING INSTALLER AT THE DISCRETION OF THE ARCHITECT.

SPECIAL VALLEY CAP; FIELD FABRICATED BREAK TO VALLEY ANGLE

1" X 1" ANGLE FASTEN TO BUTT END OF PANEL BEFORE VALLEY CAP.

BERMUDA PANEL FIELD CUT OFF BUTT AND LAP UNDER OPPOSITE PANEL CONTINUOUS CAULK AT PANEL LAP AS PER BP-71

BERRIDGE BERMUDA PANEL

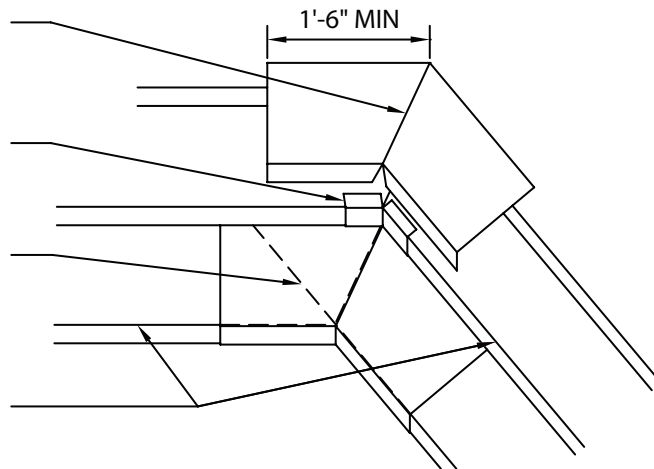

**BERRIDGE
MANUFACTURING
COMPANY**

VALLEY DETAIL

Bermuda Panel System

DATE: 08-15-06

PAGE/FILE
BP-70

FIELD FORM PANEL TO VALLEY

BERMUDA PANEL FIELD CUT
AND LAP PANELS AT VALLEY
CONTINUOUS CAULK AT LAPS

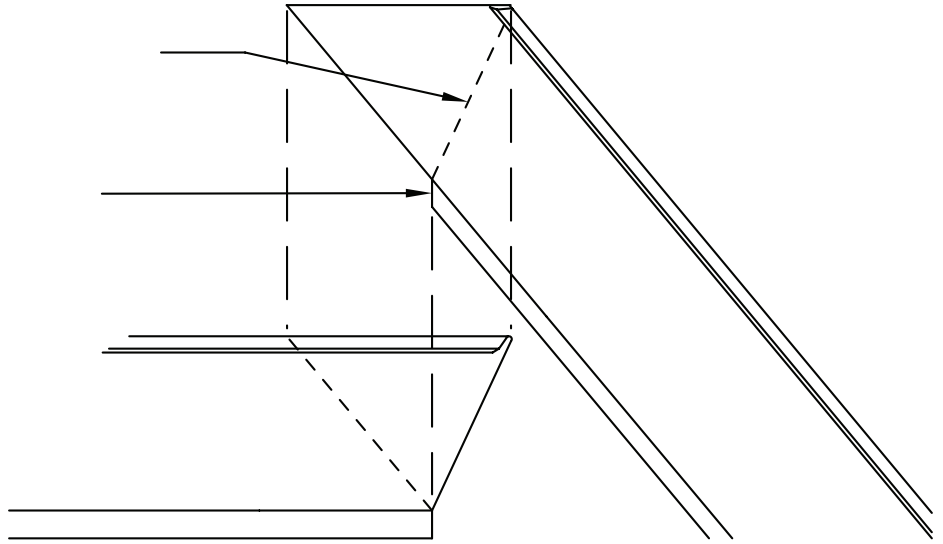

NOTE; REFER TO BP-70 FOR VALLEY DETAIL



**BERRIDGE
MANUFACTURING
COMPANY**

VALLEY DETAIL

Bermuda Panel System

DATE: 08-15-06

PAGE/FILE
BP-71

BERRIDGE BERMUDA PANEL

SPECIAL CHANNEL CLOSURE;
SET TIGHT UP TO VALLEY FLASHING
DO NOT USE FASTENERS AT
SPECIAL CHANNEL CLOSURE

CONTINUOUS BEAD OF CAULK
BETWEEN VALLEY FLASHING
AND FELT UNDERLAYMENT

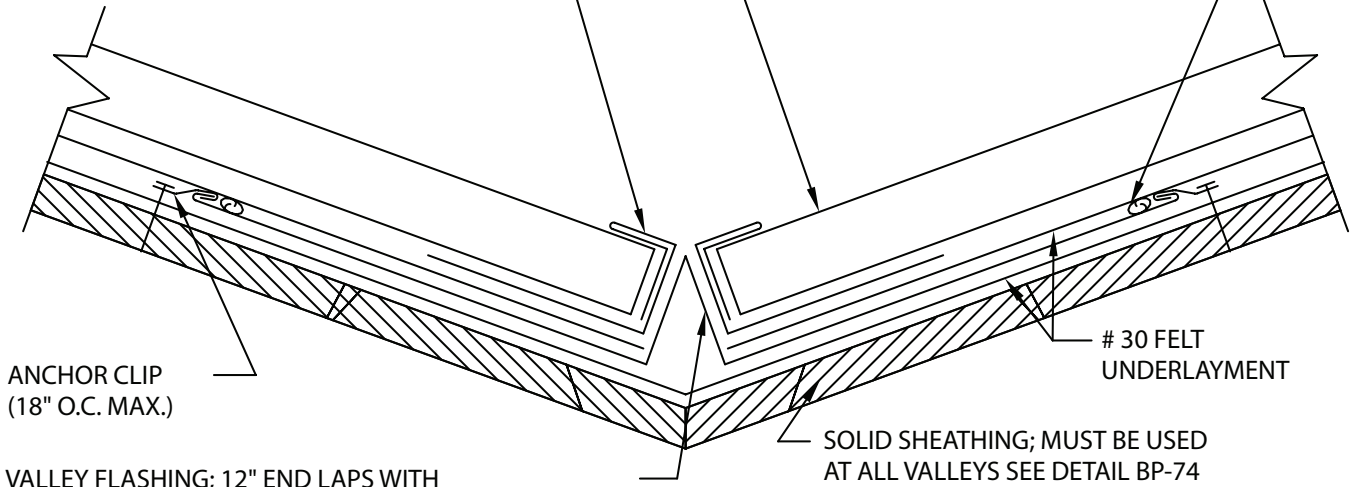

ANCHOR CLIP
(18" O.C. MAX.)

30 FELT
UNDERLAYMENT

VALLEY FLASHING; 12" END LAPS WITH
2 BEADS CONTINUOUS CAULK AT LAPS,
FASTEN UNDER LAPS ONLY

SOLID SHEATHING; MUST BE USED
AT ALL VALLEYS SEE DETAIL BP-74

NOTE: DO NOT USE ANY FASTENERS THROUGH THE VALLEY FLASHING, EXCEPT
AT LAPS (SEE DETAIL BP-73)

1. SOLID SHEATHING (BY OTHERS) TO BE A MINIMUM OF 1/2" PLYWOOD OR EQUIVALENT
IN STRENGTH FOR HOLDING POWER OF FASTENERS.
2. ALL FELT UNDERLAYMENT, CAULKING, AND FASTENERS, ARE ITEMS TO BE FURNISHED
AND INSTALLED BY THE ROOFING INSTALLER AT THE DISCRETION OF THE ARCHITECT.

F = FINISH SIDE

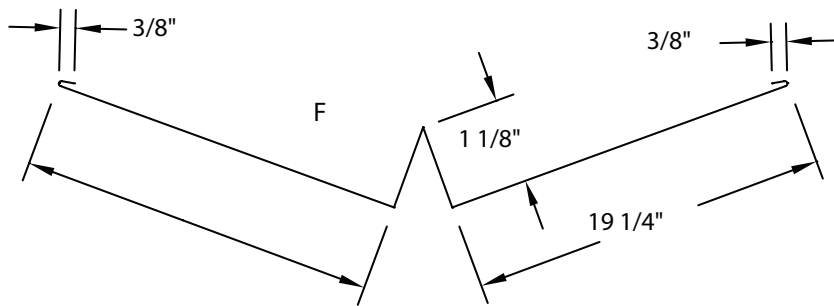

VALLEY FLASHING

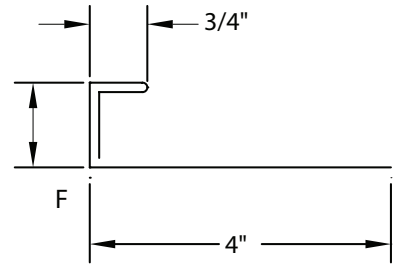

SPECIAL CHANNEL CLOSURE



BERRIDGE
MANUFACTURING
COMPANY

VALLEY DETAIL

Bermuda Panel System

DATE: 08-15-06

PAGE/FILE
BP-72

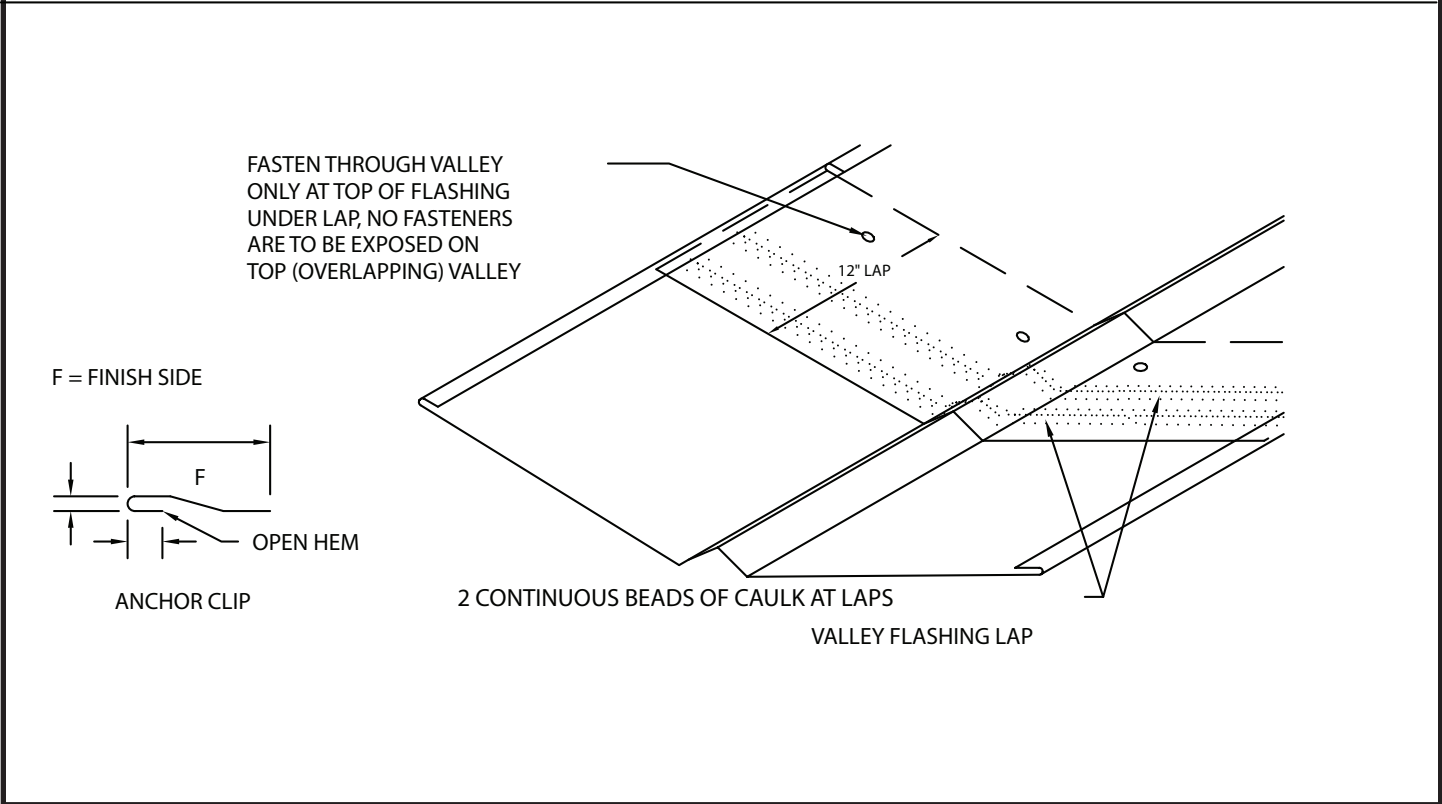
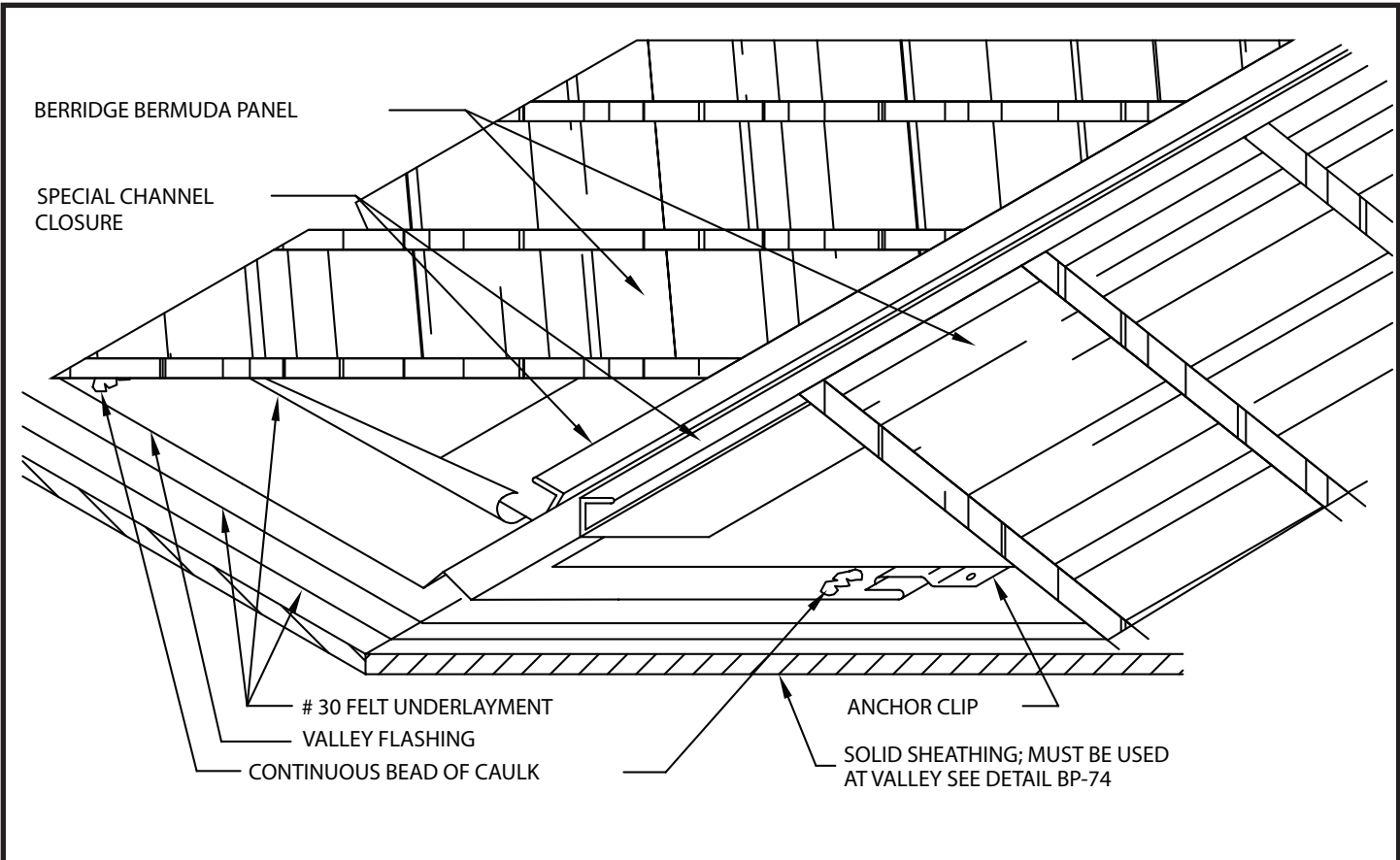

BERRIDGE
MANUFACTURING
COMPANY

VALLEY DETAIL
ISOMETRIC

Bermuda Panel System

DATE: 08-15-06

PAGE/FILE
 BP-73

GRACE ICE AND
WATER SHIELD
RUN RIDGE
TO EAVE

FLAT SHEET
VALLEY
SUB-FLASHING
RUN RIDGE
TO EAVE

BERRIDGE
CORRUGATED
S-DECK

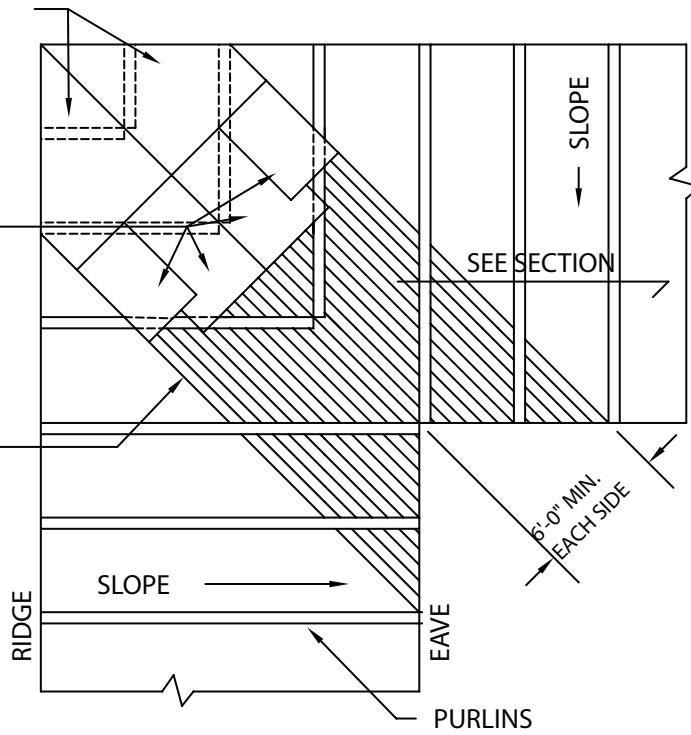

FLAT SHEET
VALLEY SUB-FLASHING

GRACE ICE AND
WATER SHIELD

16 GA.
HAT SECTION

PURLIN

BERRIDGE
CORRUGATED S-DECK

SECTION

16 GA. HAT SECTION SIZED
TO FIT OVER PURLIN AND
TO ACCOMMODATE THE DEPTH
OF THE "S" DECK.

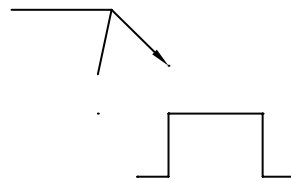

NOTE; GRACE ICE AND WATERSHIELD TO BE USED FOR THIS CONDITION.
DO NOT USE FELT AT THIS CONDITION. (SEE DETAIL BP-70 & BP-71)



**BERRIDGE
MANUFACTURING
COMPANY**

Roofs of Distinction

**VALLEY DETAIL
OPEN FRAMING**

Bermuda Panel System

DATE: 08-15-06

PAGE/FILE
BP-74

ROOF PIPE PENETRATION
OF 4" DIA. OR LESS

RUBBERIZED "BOOT"
FLASHING

PIPE PENETRATION TO
BE IN PAN OF PANEL ONLY

BERRIDGE BERMUDA
PANEL

CUT PANEL 1" SMALLER THAN
PENETRATION, BACK CUT TABS,
FOLD TABS UP AROUND
PENETRATION, AND CAULK.

CONTINUOUS CAULK OR
STAINLESS STEEL HOSE
CLAMP

SET RUBBERIZED BOOT
INTO CONTINUOUS BEAD
OF CAULK. USE FASTENERS
AS SPECIFIED BY BOOT
MANUFACTURER. CAULK
FASTENER HEADS.

30 FELT UNDERLAYMENT

SOLID SHEATHING

1. CUT HOLE TO ALLOW FOR THERMAL MOVEMENT IF PANELS ARE 30'-0" OR LONGER.
2. IF PIPE IS MADE OF METAL, IT MUST BE PAINTED TO PREVENT RUST RUN-OFF FROM STAINING PANELS.
3. POSITION SQUARE BASED BOOTS IN A DIAMOND ORIENTATION WHERE POSSIBLE TO AID IN DIVERTING WATER.



**BERRIDGE
MANUFACTURING
COMPANY**

PIPE PENETRATION
OPEN FRAMING AND
SOLID SUBSTRATE

Bermuda Panel System

DATE: 08-15-06

PAGE/FILE
BP-80

BERRIDGE BERMUDA PANEL

WRAP CURB WITH
30 FELT UNDERLAYMENT
AND SUB FLASHING

TURN CORNER WITH
VERTICAL LEG OF FLASHING
FROM BP-82

TURN CORNER WITH
VERTICAL LEG OF STEP
FLASHING, FROM BP-83

FIELD FORM STEP FLASHING
VERTICAL LEG TO FORM
TIGHT TO PANEL, 4" LAP
WITH CONTINUOUS CAULK
AT LAPS

TURN CORNER WITH
VERTICAL LEG OF STEP
FLASHING, FROM BP-83

TURN CORNER WITH
VERTICAL LEG OF COUNTER
FLASHING, FROM BP-82

CARRY STEP FLASHING FROM
BP-83 UNDER FLASHING
FROM BP-82

BP-83

CONTINUOUS CAULK
AT ALL FLASHING LAPS

BP-82

SLOPE

BERRIDGE BERMUDA PANEL

NOTE: PANELS ARE TO BE
FIELD CUT TO FIT TIGHT
AROUND PENETRATION



**BERRIDGE
MANUFACTURING
COMPANY**

**ROOF PENETRATION
RECTANGULAR/SQUARE**

Bermuda Panel System

DATE: 08-15-06

PAGE/FILE
BP-81

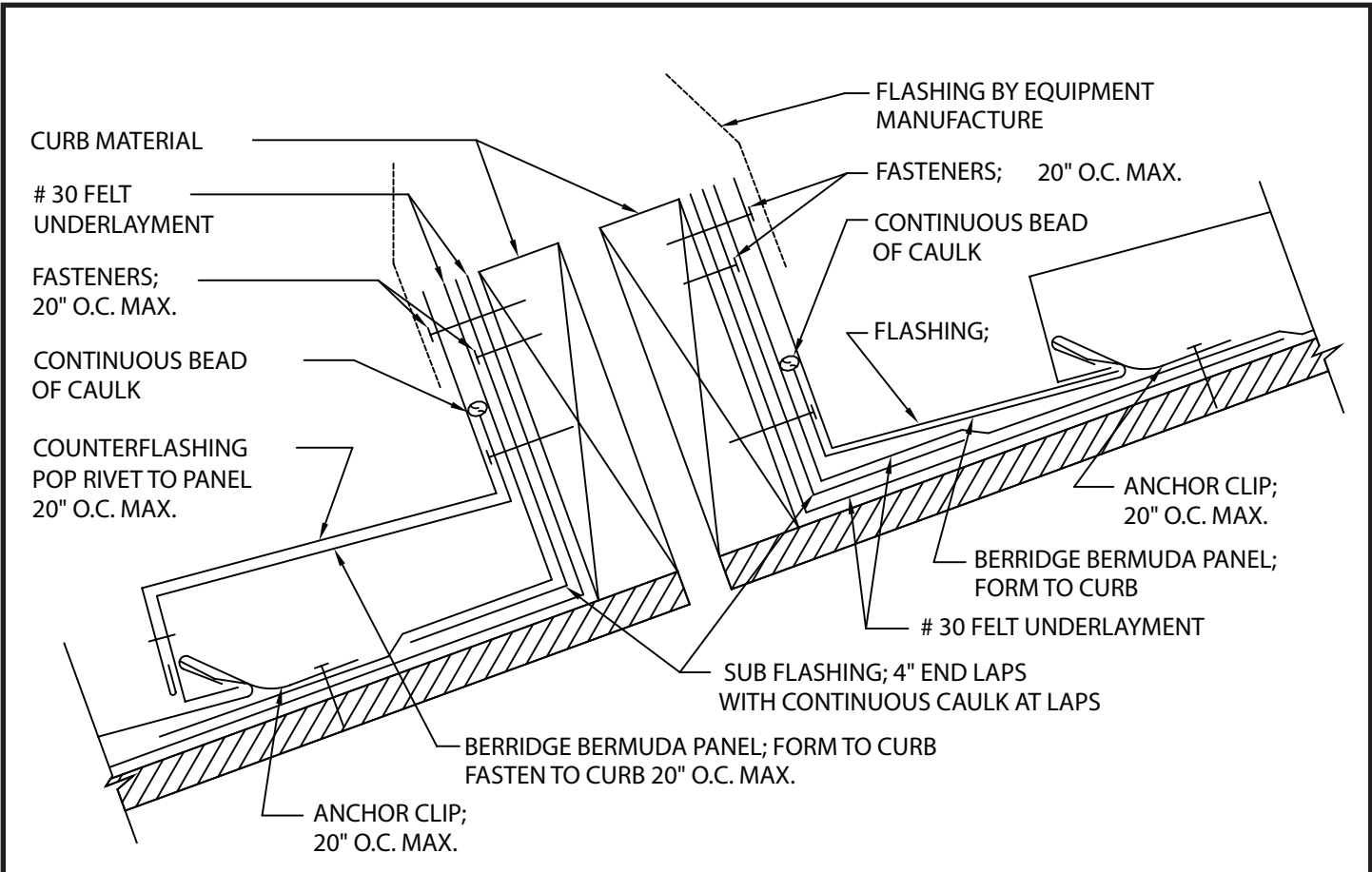

1. SOLID SHEATHING IS REQUIRED AT THIS CONDITION WHEN THE BERMUDA PANEL IS USED OVER OPEN FRAMING (SEE DETAIL BP-84).
2. SOLID SHEATHING (BY OTHERS) TO BE MINIMUM 1/2" PLYWOOD OR EQUIVALENT IN STRENGTH FOR HOLDING POWER OF FASTENERS. (METAL CORRUGATED SHEATHING MAY BE USED IN LIEU OF PLYWOOD).
3. ALL FELT UNDERLAYMENT, CAULKING, AND FASTENERS, ARE ITEMS TO BE FURNISHED AND INSTALLED BY THE ROOFING INSTALLER AT THE DISCRETION OF THE ARCHITECT.

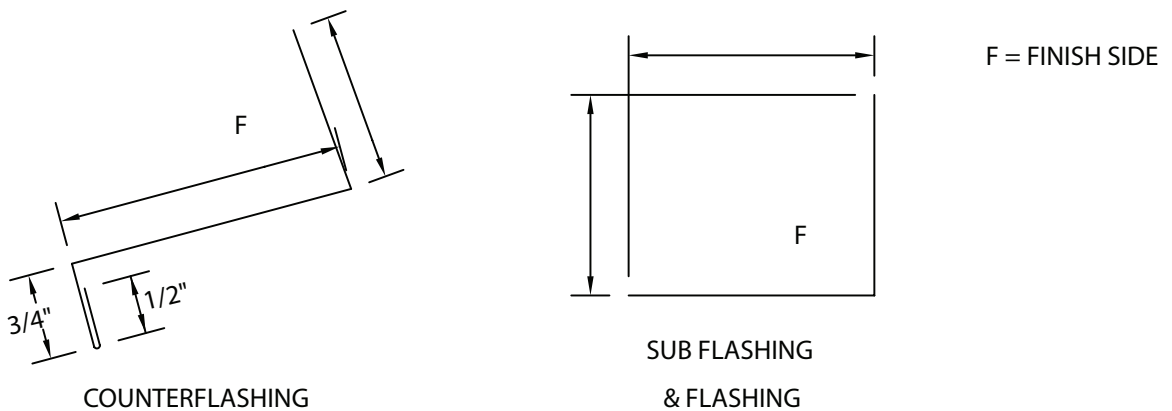

**BERRIDGE
MANUFACTURING
COMPANY**

Roofs of Distinction

SQUARE PENETRATION
SECTION A
SOLID SUBSTRATE AND OPEN FRAMING

Bermuda Panel System

DATE: 08-15-06

PAGE/FILE
BP-82

FLASHING BY
EQUIPMENT MANUFACTURE

STEP FLASHING; 4" END LAPS WITH
CONTINUOUS CAULK AT LAPS, SET
FLASHING TIGHT ON TO PANEL

BERRIDGE BERMUDA PANEL;

30 FELT
UNDERLAYMENT;
TOP LAYER TO BE
PARALLEL WITH
ROOF SLOPE

SUB-FLASHING; 4" END
LAPS WITH CONTINUOUS
CAULK AT LAPS

FASTENERS; 20" O.C. MAX.

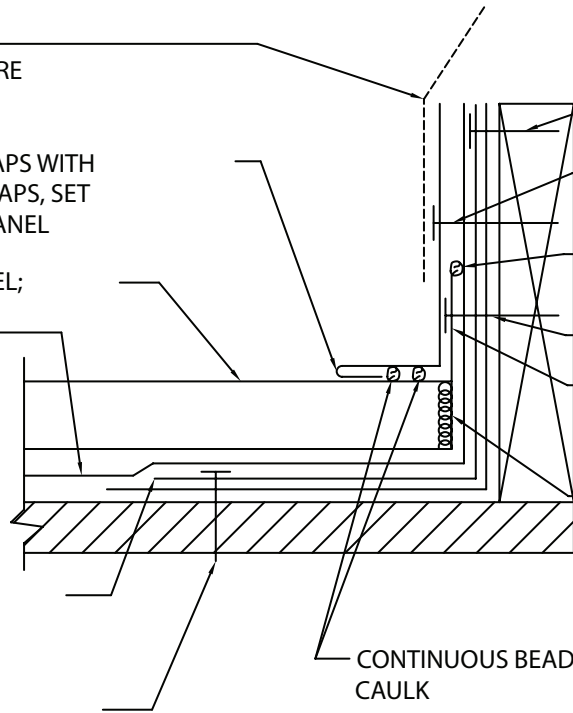

FASTENERS; 20" O.C. MAX.

FASTENERS EVERY 11" O.C. AT
LOCATION OF MALE/FEMALE JOINT

CONTINUOUS BEAD OF
CAULK

FASTENERS; 2 PER PANEL LEG

FIELD CUT PANEL AND TURN
UP VERTICAL LEG AT END OF
PANEL MINIMUM 2"

CONTINUOUS CAULK ALONG
VERTICAL EDGE OF BERMUDA
PANEL

CONTINUOUS BEAD OF
CAULK

1. SOLID SHEATHING IS REQUIRED AT THIS CONDITION WHEN THE BERMUDA PANEL IS USED OVER OPEN FRAMING (SEE DETAIL BP-84).
2. SOLID SHEATHING (BY OTHERS) TO BE MINIMUM 1/2" PLYWOOD OR EQUIVALENT IN STRENGTH FOR HOLDING POWER OF FASTENERS. (METAL CORRUGATED SHEATHING MAY BE USED IN LIEU OF PLYWOOD).
3. ALL FELT UNDERLAYMENT, CAULKING, AND FASTENERS, ARE ITEMS TO BE FURNISHED AND INSTALLED BY THE ROOFING INSTALLER AT THE DISCRETION OF THE ARCHITECT.

F = FINISH SIDE

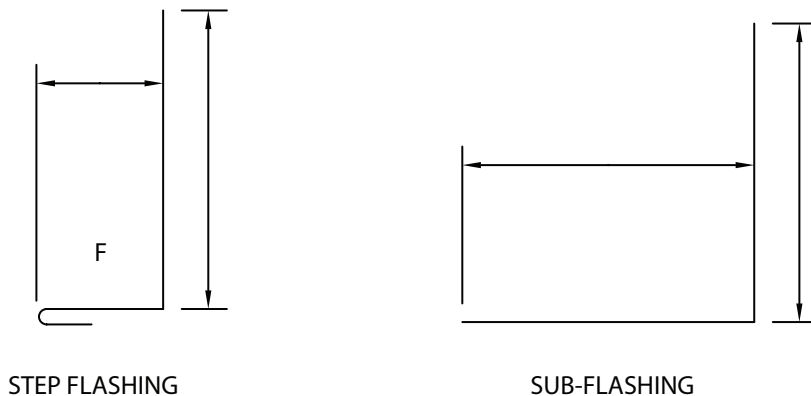

STEP FLASHING

SUB-FLASHING



**BERRIDGE
MANUFACTURING
COMPANY**

SQUARE PENETRATION
SECTION B
SOLID SUBSTRATE AND OPEN FRAMING

Bermuda Panel System

DATE: 08-15-06

PAGE/FILE
BP-83

FOR ROOF PENETRATIONS
LARGER THAN 4" IN DIA.

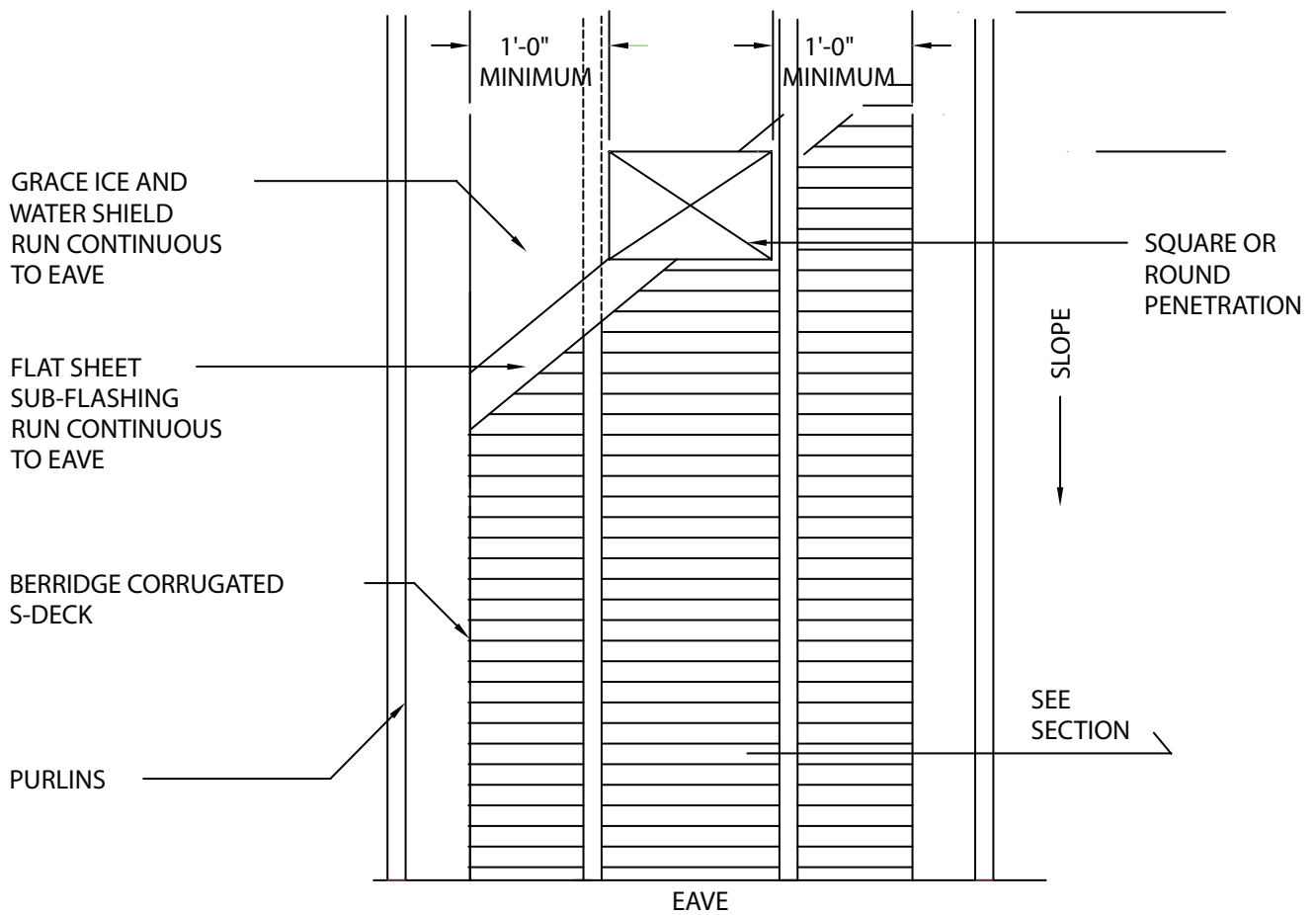

16 GA. HAT SECTION SIZED TO FIT OVER PURLIN AND TO ACCOMMODATE THE DEPTH OF THE "S" DECK.

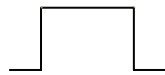

FLAT SHEET SUB-FLASHING
GRACE ICE AND WATER SHIELD

16 GA. HAT SECTION PURLIN

BERRIDGE CORRUGATED S-DECK

SECTION

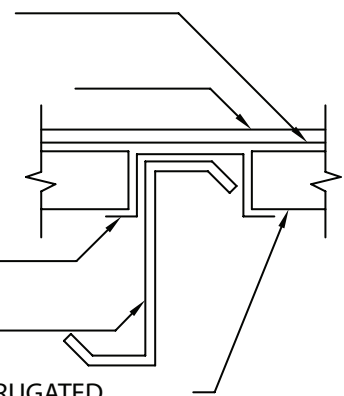

BERRIDGE
MANUFACTURING
COMPANY

Roofs of Distinction

PENETRATION OPEN FRAMING

Bermuda Panel System

DATE: 08-15-06

PAGE/FILE
BP-84

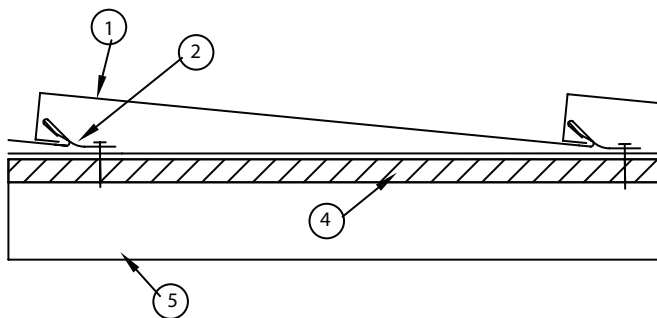
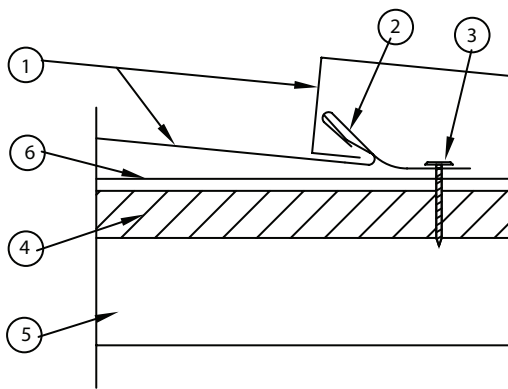
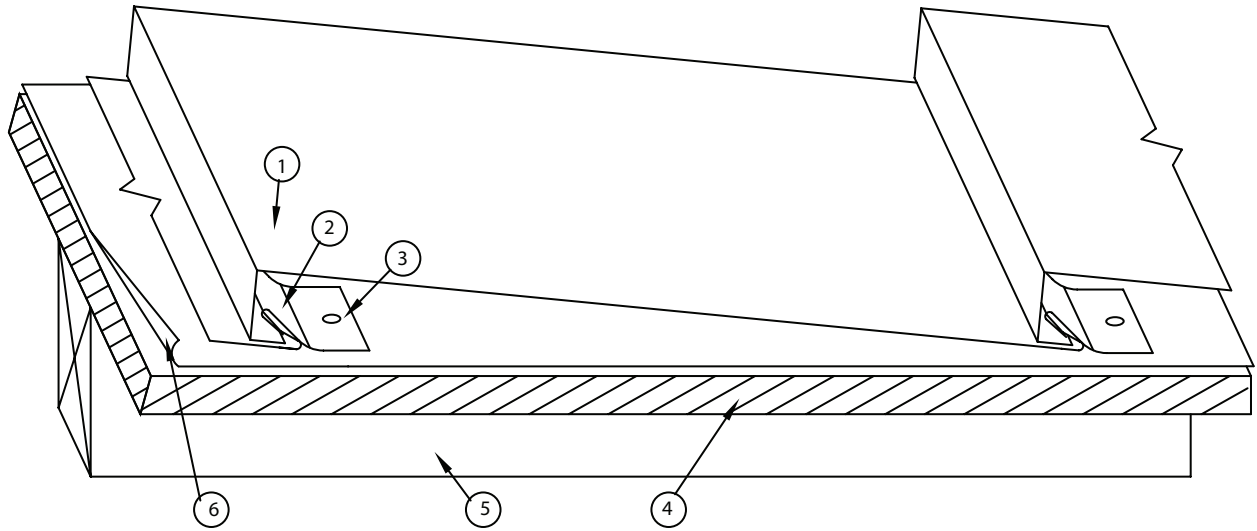

BERRIDGE BERMUDA ROOF PANEL OVER SOLID WOOD SHEATHING WITH CLIPS

COMPONENTS:

1. BERRIDGE BERMUDA PANEL: 24 GA. (MIN. YIELD 40,000 PSI) COATED STEEL, 11" W X 1" HIGH.
2. BERMUDA PANEL CLIPS: ONE PIECE, FABRICATED FROM 24 GA. (MIN. YIELD 40,000 PSI) COATED STEEL. LOCATED AT PANEL LAPS, 2'-0" MAX. SPACING.
3. FASTENERS: USE ONE (1) NO. 10 PANCAKE HEAD "TEKS" SCREW STEEL SCREW PER CLIP LOCATION.
4. DECK: 5/8" APA 40/20 PLYWOOD.
5. JOISTS: 2" X 4" @ 2'-0" O.C. MAX. W/#12 X 2" PAN HEAD WOOD SCREWS @ 12" O.C. MAX. @ PLYWOOD TO JOIST CONNECTION AND AT PLYWOOD ENDS.
6. FELT PAPER: 1 LAYER # 30 ROOFING FELT, LAID HORIZONTALLY, EAVE TO RIDGE.



**BERRIDGE
MANUFACTURING
COMPANY**

Roofs of Distinction

U.L. 90 CONST. NO. 405
BERRIDGE BERMUDA ROOF PANEL
OVER SOLID WOOD SHEATHING

Bermuda Panel System

DATE: 08-15-06

PAGE/FILE
BP-90