

USE ONLY STAINLESS STEEL OR ALUMINUM LIGHTNING RODS

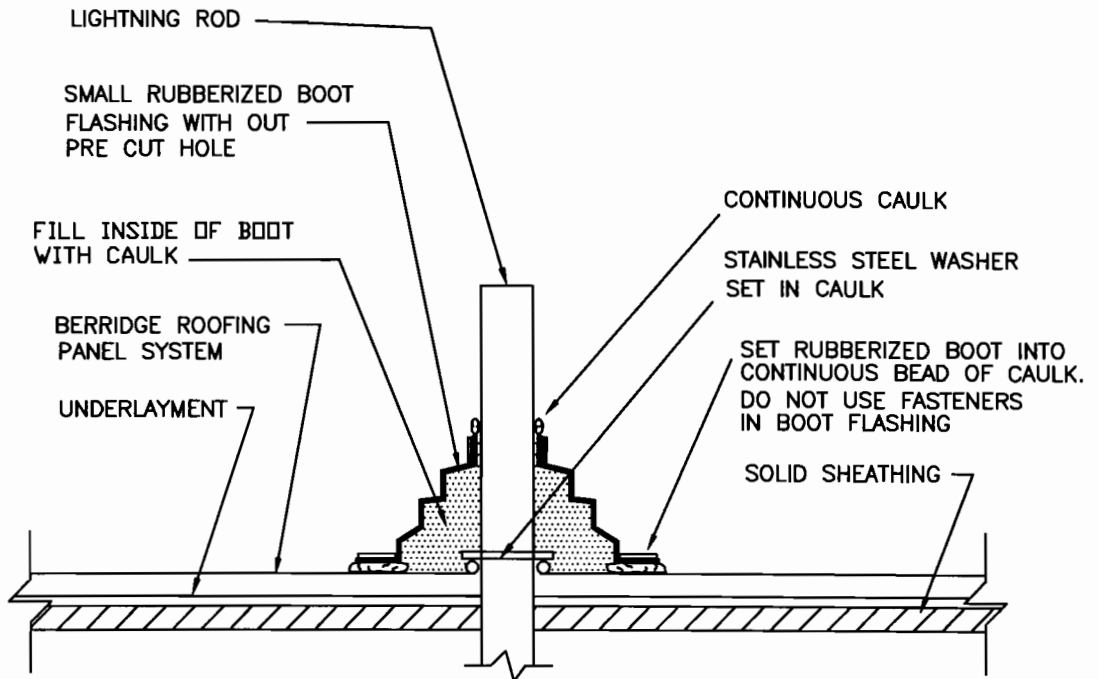

Lightning control systems on a project are to the discretion of the Architect or project designer. Berridge Manufacturing Co. makes no recommendations as to when to use a lightning control system.

However if a lightning control system is specified, all components of the system should be of material compatible with the Berridge roofing system, aluminum and or a stainless steel are two metals that work well. When an incompatible material such as copper is used, electrolytic corrosion (Electrolysis) occurs. When dissimilar metals are in contact in the presence of an electrolyte, such as water (moisture). The dissimilar metals set up a galvanic action that results in the deterioration of one of them (the Berridge roofing system). Berridge Manufacturing Co. will not be held liable for any claims due to failures caused by dissimilar metals.

Lightning control system normally require anchorage for the air terminals and the cable bases. If anchorage is made with an adhesive to the Berridge roofing system compatibility to Kynar / Hylar paint should be investigated. If cutting holes in the Berridge roofing system is required for anchorage, rubberized boots should be used and sealed to the Berridge roof system with Tremco Spectrem One caulking (refer to the manufacture of the lightning control for suitable boots). Note it is possible that cables can vibrate in the wind and cause damage to the metal and paint finish, therefore the cables should not be allowed to lay on top of the roofing panels or flashings.

Berridge Manufacturing will not be responsible for watertightness of the installation of the lightning control system this is a matter which should be covered by the lightning control system installer or lightning control manufacturer.

Lightning control system are to be designed by and installed by qualified professionals, Berridge Manufacturing Co. shall have no liability to the recommendations outlined in this letter.



**Berridge  
Manufacturing  
Company**

Roofs of Distinction

LIGHTNING ROD

DATE: 9/11/06

**PANEL SYSTEMS**

PAGE \ FILE  
1 of 1