

PRODUCT DESCRIPTION

NO. PD 694-1

HIGH SEAM TEE-PANEL WITH RIGID PROFILE STRIATIONS

- Virtually eliminates "oil-canning" or waviness
- Smoother, more subtle and aesthetic appearance than ribs or corrugations.
- Permits Curving to Minimum 8' or 20' radius*
- Corrects minor loose spots in pans

Since no architectural metal roofing is totally free of a certain degree of waviness, which is sometimes referred to as "oil-canning", Berridge has introduced a mildly striated version of its popular High Seam Tee-Panel standing seam roof panel, referred to as **RIGID PROFILE**. These gradual, subtly formed vee-shaped striations (Figures 1 & 2) are two inches wide and three thirty-seconds of an inch deep. By introducing just a hint of corrugation into the flat architectural metal pans, this mild striation process effectively removes or hides loose spots or distortions caused by mill camber or other minor imperfections.

From an aesthetic point of view, the use of subtle striations is distinctly superior to the introduction of pencil ribs, grooves or other more obvious corrugation or roll forming process; In fact the striations in installed **RIGID PROFILE** High Seam Tee-Panels is virtually undetectable. Best of all, panels with mild striations exhibit virtually no "oil-canning", buckling or waviness.

Because not all Berridge portable roll formers are equipped with the special striation roller stand, the Berridge Licensee or architect should specify that the panel is to utilize the new **RIGID PROFILE** and allow sufficient lead time to schedule delivery of an appropriately configured machine.

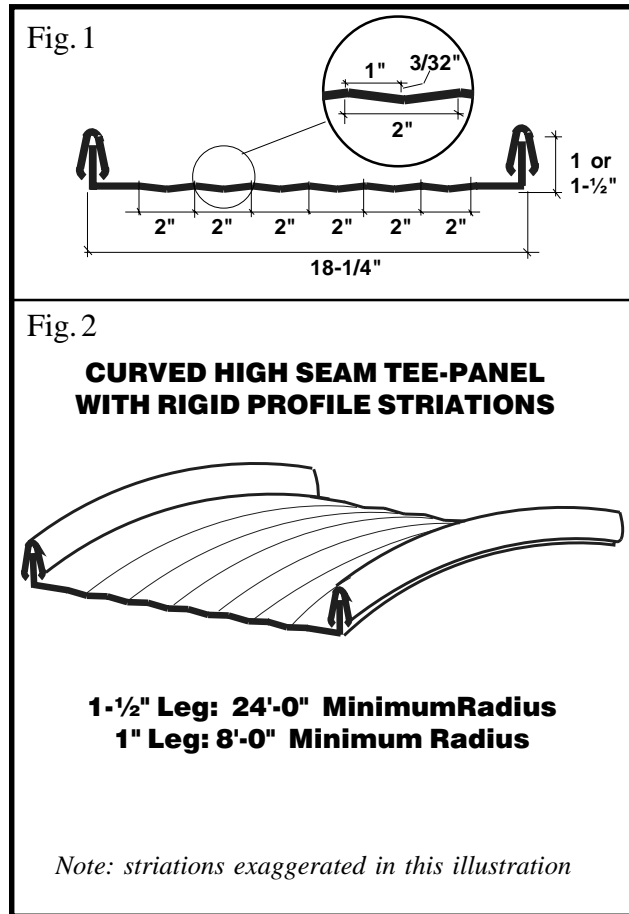

HIGH SEAM TEE-PANEL WITH RIGIDIZED PROFILE
Berridge Manufacturing Company



7

Moisture & Thermal Protection:
Metal Roofing & Siding Products



BERRIDGE MANUFACTURING COMPANY

1720 MAURY STREET / HOUSTON, TEXAS / 77026 / (713) 223-4971 / 1-800-231-8127 / FAX 713-236-9422