

OPERATIONS MANUAL

BERRIDGE MODEL CL-21 PORTABLE ROLL FORMER

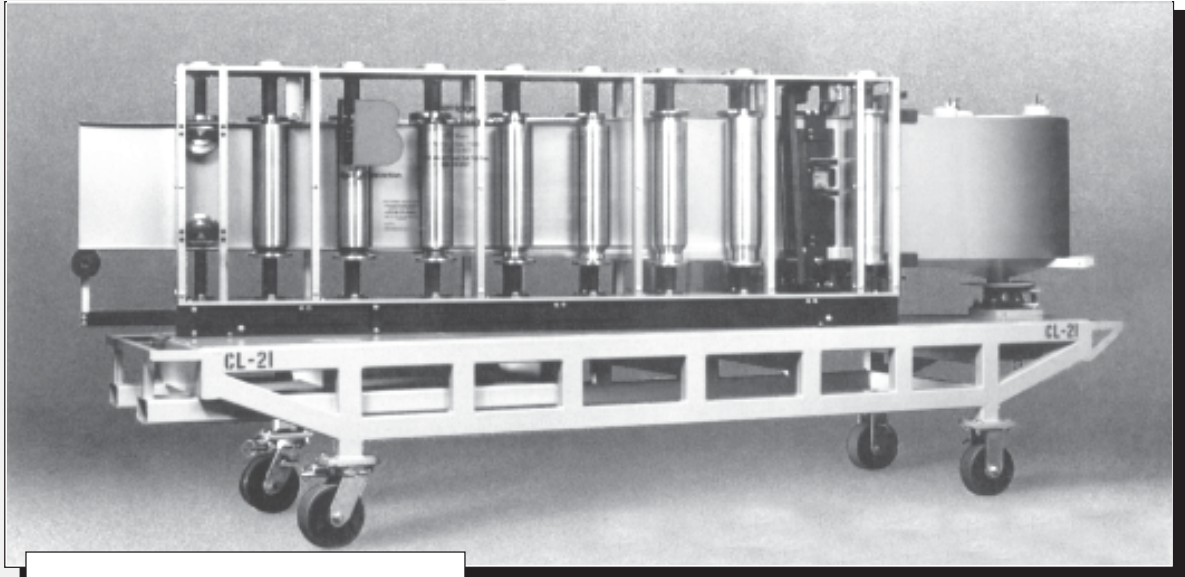

BERRIDGE
B Berridge
Manufacturing
Company

LEASED TO: _____

DATE: _____ SER. NO.: _____

CONTENTS

I. GENERAL DESCRIPTION	2
II. EQUIPMENT NOMENCLATURE	3
III. OPERATING INSTRUCTIONS	4
IV. MAINTENANCE INSTRUCTIONS	5
V. SAFETY	6
VI. ROLL FORMER RETURN INFORMATION FORM	7

I. GENERAL DESCRIPTION

THE BERRIDGE MODEL CL-21 PORTABLE ROLL FORMER is a precision-manufactured machine designed to provide high quality "Jobsite" production capability for installers of the BERRIDGE CEE-LOCK standing seam roof panel (Fig. 1).

Fig. 1

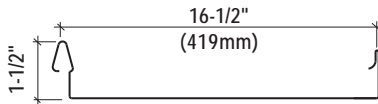

THE BERRIDGE MODEL CL-21 PORTABLE ROLL FORMER is mounted on a heavy-duty four wheel cart and is completely self-contained, including uncoiler, mechanical shear and counter gauge for measuring panel length.

CASTER BRAKES & LOCKING MECHANISM:

For safety reasons, it is recommended that the foot brakes on each caster be placed in the locked position whenever the roll former is not being moved. Also, note the two front casters have a locking mechanism to keep them from swiveling. This is useful when pulling the cart onto the Berridge Trailer.

MODEL CL-21 COIL USAGE:

Coil material used with the Berridge Model CL-21 Portable Roll Former must comply with the following parameters:

- Coil Width 20.875 inches (nom. 21")
- Maximum Weight 2000 Lbs.
- Maximum Outside Diameter 32 Inches
- Minimum Inside Diameter 20 Inches
- Maximum Material Thickness 24 Ga. (.024 In.)
- 22 Ga. available on request.

Material: Prefinished galvanized or Galvalume,
16 oz. ¼-½ hard Copper

NOTE: Do not run unpainted coil on the CL-21 Portable Roll Former; Unpainted coil may cause flake build-up on rolls. Because the CL-21 is a precision machine, designed to fabricate only Berridge-developed products, only Berridge Coil may be used in these roll-formers. Other coil material may vary in thickness, hardness, and surface treatment which could damage the components of the CL-21 Roll-Former. Also, defective coil material will result in a defective product which could damage the reputation of the high quality Berridge products. Therefore, only Berridge coil is allowed to be used in any Berridge Portable Roll-Former. If it is discovered that any other material has been used in a Berridge Portable Roll-Former, Berridge Manufacturing Company has the right to recall the machine and completely disassemble and inspect it. A service charge will be assessed.

TRANSPORTING THE CL-21:

Never transport the machine without a piece of coil remaining in contact with all rolls. This keeps the rolls from moving while in transit and becoming scarred or damaged. Do not transport the roll former with a coil loaded on the uncoiler unless the uncoiler is blocked to support the weight of the coil.

ELECTRICAL POWER REQUIREMENTS:

The Berridge Model CL-21 Portable Roll Former requires standard U.S. electrical current of 220 volt single phase power. Connect to a grounded supply receptacle with at least 20 amp current capacity. If extension cords are required, use the following recommended sizes:

Length	Wire Gauge
0-100 FT	10
100+ FT	8

NOTE: The use of portable electric generators to power the Model CL-21 is not recommended, as this practice will lead to damage to the electric motor.

II. EQUIPMENT NOMENCLATURE

MODEL CL-21 PORTABLE ROLL-FORMER

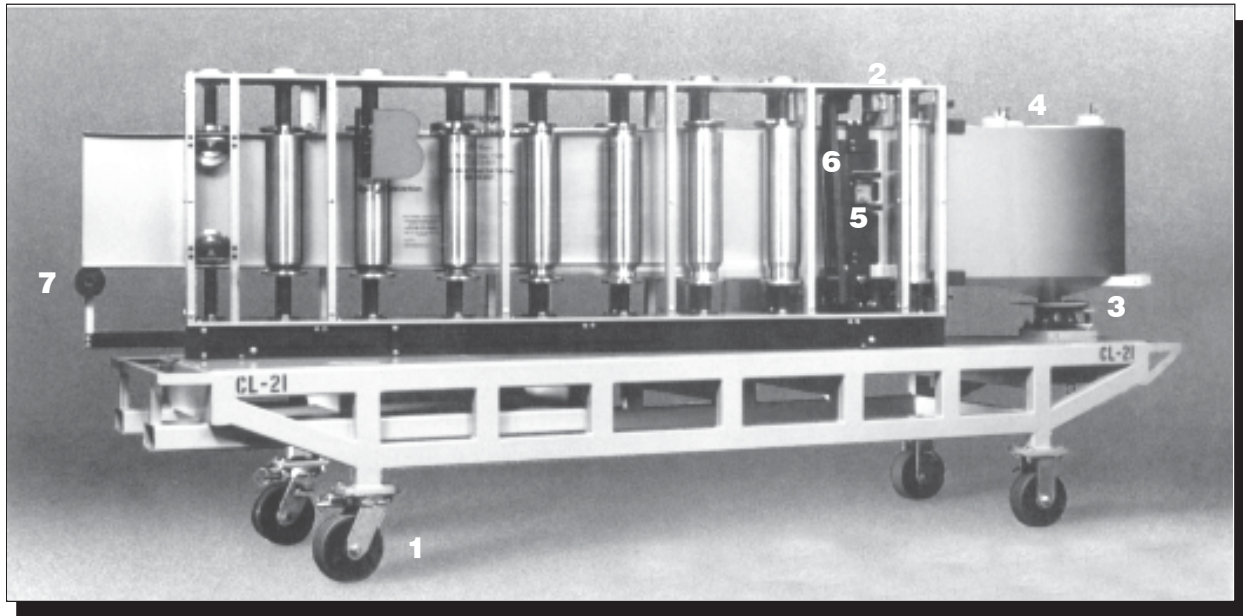

FEATURES:

1. CASTERS
2. DRUM SWITCH
3. BRAKE ADJUSTMENT
4. UNCOILER
5. COUNTER GAUGE
6. SHEAR HANDLE
7. PANEL SUPPORT BAR & ROLLER

NOT SHOWN:

VINYL UNCOILER & SHEAR KNOB

ROLL FORMER SPECIFICATIONS

WIDTH: 2'-10"
LENGTH: 12' - 6"
HEIGHT: 5'
WEIGHT: 3100 LBS (3170 LBS W/METAL COVER)
SPEED: 45' PER MINUTE
MOTOR:
22 & 24 GA.
ROLLFORMERS: 2 H.P. 240V. AC ELECTRIC

III. OPERATING INSTRUCTIONS

STEP ONE - LOADING COIL

- A. Lock all four casters.
- B. Rotate the eccentric tubes (Detail B-2) on the uncoiler by loosening the nuts on top of tubes (Detail B-1). Then rotate tubes inward to accept the coil.
- C. Load the coil with painted side facing toward operator side of rollformer, with leading edge toward the machine.
- D. Unlock arm of the coil lifter apparatus (Detail C-1), fold legs inward (Detail C-2) and place inside the coil (Detail C-3). The coil lifter legs should now be locked in place and the coil should be fully seated on the pads of the coil lifter legs.
- E. Using a forklift or other suitable hoist with a minimum load capacity of 2000 pounds, pick up the coil by means of a chain (sized to accommodate load) attached to the top of the coil lifter. Keep to one side of coil and avoid standing underneath it during the loading operation. Next, lower the coil onto the uncoiler, and keep it centered on the uncoiler with the leading end positioned clockwise, ready to feed into the machine.

STEP TWO - FEEDING COIL INTO THE ROLLFORMER:

- A. Shear handle must be in the upright position. If using a pivot style shear, slit shears need to be all the way down and resting on the bottom plate.
- B. The Drum Switch located on the side of the rollformer controls the direction of the coil through the rolls. With the switch in the forward mode, the coil will proceed through the various forming stages. At this time, run any metal left in the rolls through the machine to make way for the new coil. Turn Drum Switch to forward; motor will start but rollers will not turn. To feed the coil through machine, press green job button located above shear station.
- C. Clip the corners of the leading edge of the coil before feeding into the rolls.
- D. By hand (**DO NOT TOUCH DRUM SWITCH DURING THIS SEQUENCE**) insert the leading end of the coil through the slot in the plastic guard and let it slide on the lower support bar until the coil enters the first set of rolls.
- E. Turn the Drum Switch to the forward mode, apply some hand pressure on the coil (KEEP HANDS CLEAR OF INSIDE THE PLEXIGLAS) to force it into the rolls and down on the support bar until it feeds by itself.
- F. If the uncoiler moves too freely or if the material slips in the roll, it may be necessary to adjust the uncoiler brake by loosening or tightening the adjustment bolt (Detail B-3). **NOTE:** Loosen locknut and rotate bolt clockwise for increased brake pressure or counter-clockwise to decrease brake pressure.

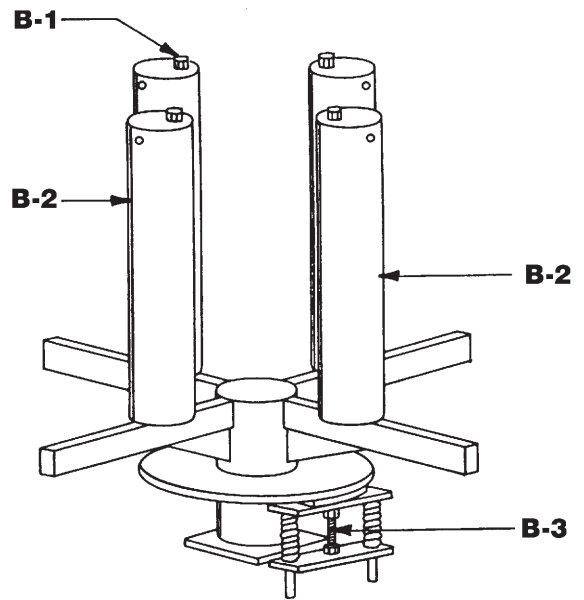

B-1 LOCKING NUTS
B-2 ECCENTRIC TUBES
B-3 BRAKE ADJUSTMENT BOLT
B-4 ECCENTRIC TUBE ADJUSTMENT TOOL

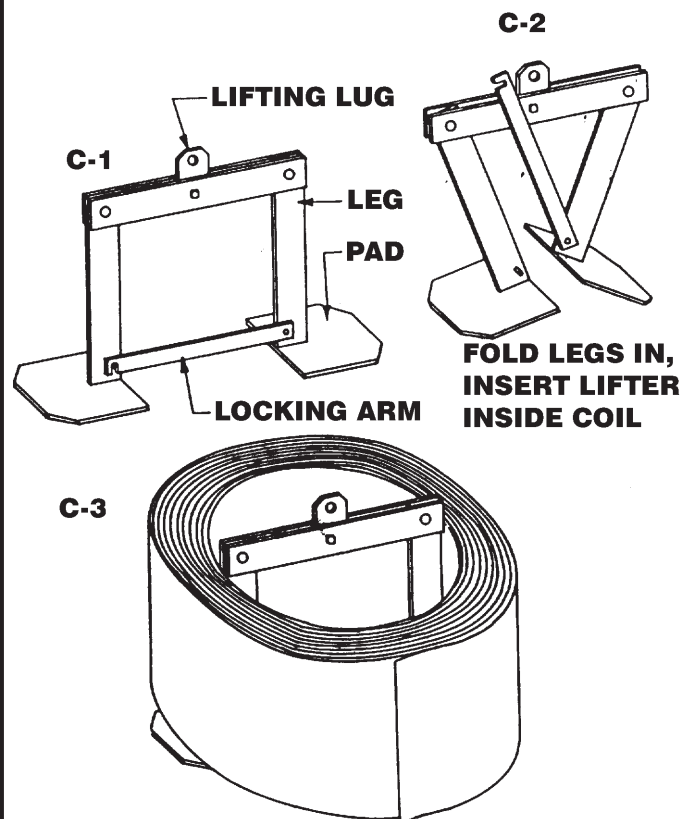

III. OPERATING INSTRUCTIONS

STEP THREE - RUNNING PANELS

- A. Allow one man for every 10 foot length of panel being run to support panel and carry without causing the panel to buckle.
- B. The panel **MUST** be held in a horizontal plane, level with the position in which it leaves the rolls. Make sure the Panel Support Roller (Item No.7 in nomenclature photo on page 3) is fully extended before running panels. If this procedure is not followed, it may result in unequal leg heights, buckling of panel or possible "oil-canning" of panel.
- C. Set the counter to zero by depressing the reset button. The counter will measure in feet and inches. There is no calibration for fractions of an inch but after experience in operation you will be able to determine stopping points on the counter for fractions. Make sure coil is dry when being run as this may cause counter to slip. Measure panels occasionally to double check counter accuracy.
- D. When you have run the panel to the desired length, release green jog button. NOTE: If you have slightly run the panel past the desired length, you can turn the drum switch to the reverse mode and back it up. It is not recommended that you do this for more than a couple of inches.
- E. Pull the shear handle down to cut the panel. NOTE: When shear handle is down, it blocks the incoming coil from entering the rolls. To run coil through rolls without starting a new panel, leave handle down after making last cut.
- F. When optional vinyl weatherseal is used, mount the vinyl spool on the vinyl uncoiler and feed vinyl into the female panel leg. Cut vinyl using shear as the panel exits the machine. Monitor each panel as it exits the machine to ensure vinyl is fully inserted into female leg.

IV. MAINTENANCE INSTRUCTIONS

THE BERRIDGE MODEL CL-21 PORTABLE ROLL FORMER requires very little maintenance. To insure the highest quality product and maximum machine life, the following routine preventative maintenance is required. Keep the machine **DRY, CLEAN & DIRT-FREE**; this is a precision piece of equipment. Keep a **MAINTENANCE LOG**.

- A. Remove Lexan panels from both sides. Clean the **CHROME ROLLS** with any penetrating type lubricant with Teflon. Berridge recommends *ZEP #45, TRI-FLOW* with Teflon. Do not spray the lubricant on the Lexan panels.
- B. Clean the **LEXAN SIDE PANELS** with glass cleaner (Windex or equiv.) and the **ALUMINUM FRAME** with liquid household cleaner. This will remove lubricant and dirt from the aluminum frame.
- C. The **SHEAR, UNCOILER** and **CASTER** may be lubricated with a good grease. Lubricate the upper and lower bearing on the Uncoiler. Do not apply grease to the drive gears on No. 1 Station as any dirt, paper etc. on the coil will collect on the grease.
- D. The **DRIVE CHAINS** may be lubricated with the same type Teflon lubricant.
- E. **MAIN DRIVE GEAR BOX:** Rexnord and Dodge boxes need no lubrication. Use SPO-244 by Lubriplate or equal in Euro Drive Gear Boxes.
- F. The **TABLE** can be cleaned with any liquid household cleaner. Touch-up as needed with Glidden "Bolt Green" paint.
- G. Lubricate the **SLIDES & SHEAR** once every 3 months.
- H. Check tightness of all **MOUNTING BOLTS & SCREWS** regularly, especially after each time the machine has been in transit.

NOTE TO LESSEES:

The Berridge Model CL-21 Roll Former Machine is shipped in good working condition and must be returned in the same condition. The cost of any required repairs for damage or deterioration caused by misuse or negligence will be charged to lessee.

V. SAFETY

It is important to abide by normal safety rules when operating the **BERRIDGE MODEL CL-21 PORTABLE ROLL FORMER**. While Berridge recommends the following minimum safety practices, the company accepts no responsibility for personal injury or property damage incurred while operating the machine.

- A. Make sure electrical outlet is grounded.
- B. Do not operate machine in rain or stand in water while operating .
- C. Make sure electrical cord is free of cuts and exposed wire.
- D. Keep hands and clothing out of the rolls and the shear blade.
- E. Keep wheels locked on the machine except when necessary to physically move it.
- F. Do not stand under coil when loading or unloading machine.
- G. Do not operate machine with plexiglass panels removed.



PORTABLE ROLLFORMER RETURN INFORMATION

DATE RETURNED _____

MODEL # _____

SERIAL # _____

COIL HOOK CRATE TARP

MISCELLANEOUS (LIST) _____

COMMENTS _____

REPAIRS: _____

LABOR COST: _____

PARTS COST: _____

FILL OUT & MAIL OR FAX TO:

BERRIDGE MANUFACTURING COMPANY
ROLL FORMER OPERATIONS
2201 Rudeloff Road
Seguin, Texas 78155
Fax: 830-303-0530



BERRIDGE MANUFACTURING COMPANY
6515 Fratt Rd., San Antonio, TX 78218

for Roll Former Technical Assistance
Call toll-free: 1 (800) 303-0811
Fax: (830) 303-0530
www.berridge.com

SALES HQ

SAN ANTONIO
6515 Fratt Rd
San Antonio, TX 78218
210-650-3050
Fax: 210-650-0379

SALES & DISTRIBUTION BRANCH OFFICES

HOUSTON
1720 Maury St
Houston, TX 77026
713-223-4971
Fax: 713-236-9422

SEGUIN
2201 Rudeloff Rd
Seguin, TX 78155
830-401-5200
Fax: 830-303-0530

DENVER
7801 E. 40th St.
Denver, CO 80207
303-322-3703
Fax: 303-322-3810

CHICAGO
1175 Carolina Dr.
W. Chicago, IL 60185
630-231-7485
Fax: 630-231-7520

ATLANTA
319 Lee Ind'l Blvd
Austell, GA 30168
770-941-5141
Fax: 770-941-7344

**BERRIDGE CALIFORNIA
SALES CORP.**

ARTESIA, CA
18732 Corby Ave.
Artesia, CA 90701
562-402-2081
Fax: 562-865-7878