

**PERFORMANCE TEST REPORT**

**Rendered to:**

**BERRIDGE MANUFACTURING COMPANY**

**SERIES/MODEL: Zee-Lock (Double Lock)**

**PRODUCT TYPE: Roof Panel System**

<b>Title</b>	<b>Summary of Results</b>
Water Resistance to Static Water Pressure Head	Pass

Reference should be made to Architectural Testing, Inc. Report No. 94188.01-801-44 for complete test specimen description and data.

## PERFORMANCE TEST REPORT

Rendered to:

BERRIDGE MANUFACTURING COMPANY  
1720 Maury  
Houston, Texas 77026

Report No.: 94188.01.01-801-44  
Revision 2: 01/08/10  
Test Dates: 12/17/09  
Report Date: 12/22/09  
Report Retention End Date:12/17/13

**Project Summary:** Architectural Testing, Inc. was contracted by Berridge Manufacturing Company to perform testing on a Series/Model Zee-Lock (Double Lock) roof panel system mockup at the Architectural Testing, Inc. test facility in Southlake, TX. Test specimen description and results are reported herein. The sample was provided by the client.

**Test Method:** The test specimen was evaluated in accordance with the following:

*ASTM E 2140-01, Standard Test Method for Water Penetration of Metal Roof Panel Systems by Static Water Pressure Head.*

### **Test Specimen Description:**

**Series/Model:** Zee Lock (Double Locked)

**Product Type:** Metal Roof Panel

**Overall Size:** 72" wide by 180" high

**Installation:** Metal roof panels installed over purlins on 60" centers. Zee rib was secured to the metal c-channel purlins with one #12 x 1" hex flange head drill point sheet metal screw at each purlin. Panels were double locked together over the zee rib. The zee rib ran full length of the roof panel. Sealant was applied to the underside of the Zee lock panel that contacts the zee rib. The assembled panel was sealed full perimeter to the test buck.

**Test Results:** The temperature during testing was 55°F. The results are tabulated as follows:

<u>Test Method</u>	<u>Title of Test</u>	<u>Results</u>
ASTM E 2140	Water Resistance (6" water head)	Pass

**Drawing Reference:** The test specimen drawings have been reviewed by Architectural Testing and are representative of the test specimen reported herein.

Detailed drawings, data sheets, representative samples of test specimens, a copy of this report, or other pertinent project documentation will be retained by Architectural Testing, Inc. for a period of four years from the original test date. At the end of this retention period, such materials shall be discarded without notice and the service life of this report will expire.

Results obtained are tested values and were secured by using the designated test methods. If test specimen contains glazing, no conclusions of any kind regarding the adequacy or inadequacy of the glass in the test specimen can be made. This report does not constitute certification of this product nor an opinion or endorsement by this laboratory. It is the exclusive property of the client so named herein and relates only to the specimen(s) tested. This report may not be reproduced, except in full, without the written approval of Architectural Testing, Inc.

For ARCHITECTURAL TESTING, INC:

---

James Sturdevant  
Laboratory Technician

---

John Waskow  
Director – Regional Operations

JS:jw

Attachments (pages): This report is complete only when all attachments listed are included.  
Appendix-A: Drawings (2)

### Revision Log

<u>Rev. #</u>	<u>Date</u>	<u>Page(s)</u>	<u>Revision(s)</u>
0	12/22/09	N/A	Original report issue
1	01/08/10	1	60" centers was 59" centers
1	01/08/10	Appendix A	Replaced drawing of plan view
2	01/08/10	Appendix A	Replaced drawing of section A-A

## **Appendix A**

### **Drawings**

15'



A-A

PURLINS @ 5' OC (TYP)

6'-4"

# PLAN VIEW



Architectural Testing

Test sample complies with these details.  
Deviations are noted.

94188.01

Tech JS

Report # 18710

Date

DATE: 12/18/2009

DRAWN BY: TA

ASTM E 2140

STANDARD TEST METHOD FOR WATER PENETRATION  
OF METAL ROOF PANEL SYSTEMS BY STATIC WATER PRESSURE HEAD

ZEE-LOCK DOUBLE-LOCK PANEL

**BERRIDGE**

Berridge  
Manufacturing  
Company

Roofs of Distinction

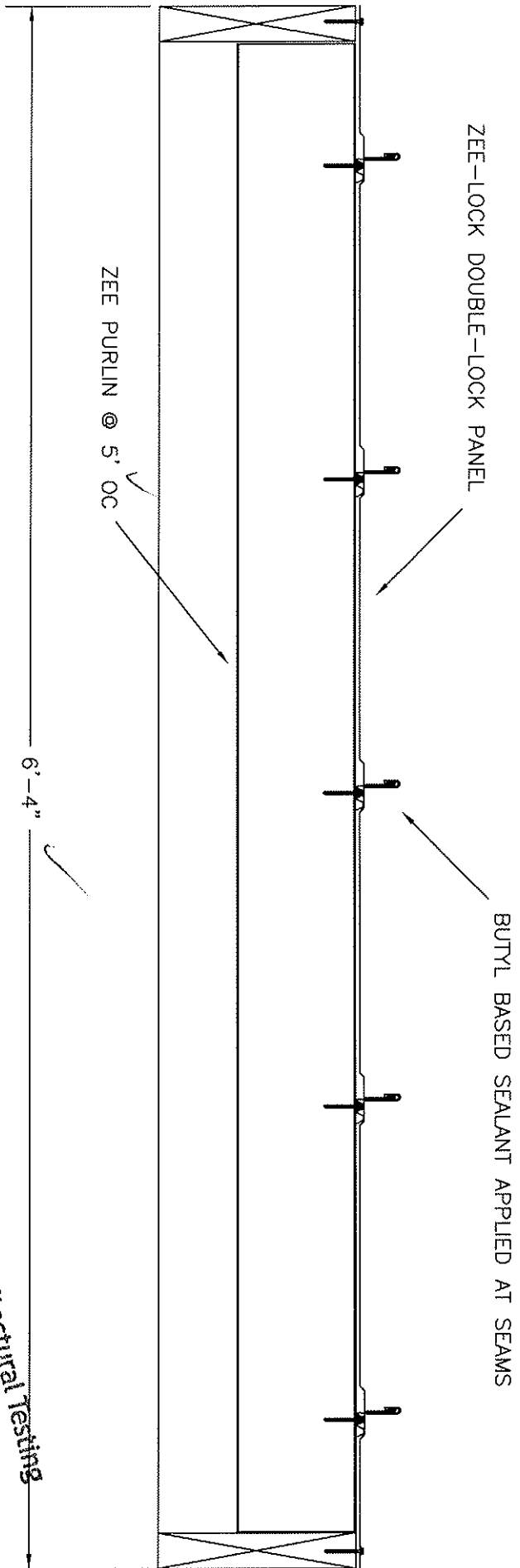

# SECTION A-A

**Architectural Testing**  
 Test sample complies with these details.  
 Deviations are noted.

Report# 94188.01  
 Date 12/10 Tech JS



**Berridge Manufacturing Company**  
 Roofs of Distinction

ASTM E 2140  
 STANDARD TEST METHOD FOR WATER PENETRATION  
 OF METAL ROOF PANEL SYSTEMS BY STATIC WATER PRESSURE HEAD

ZEE-LOCK DOUBLE-LOCK PANEL

DATE: 12/18/2009  
 DRAWN BY: TA